

Groupe Scolaire

Al Jabr

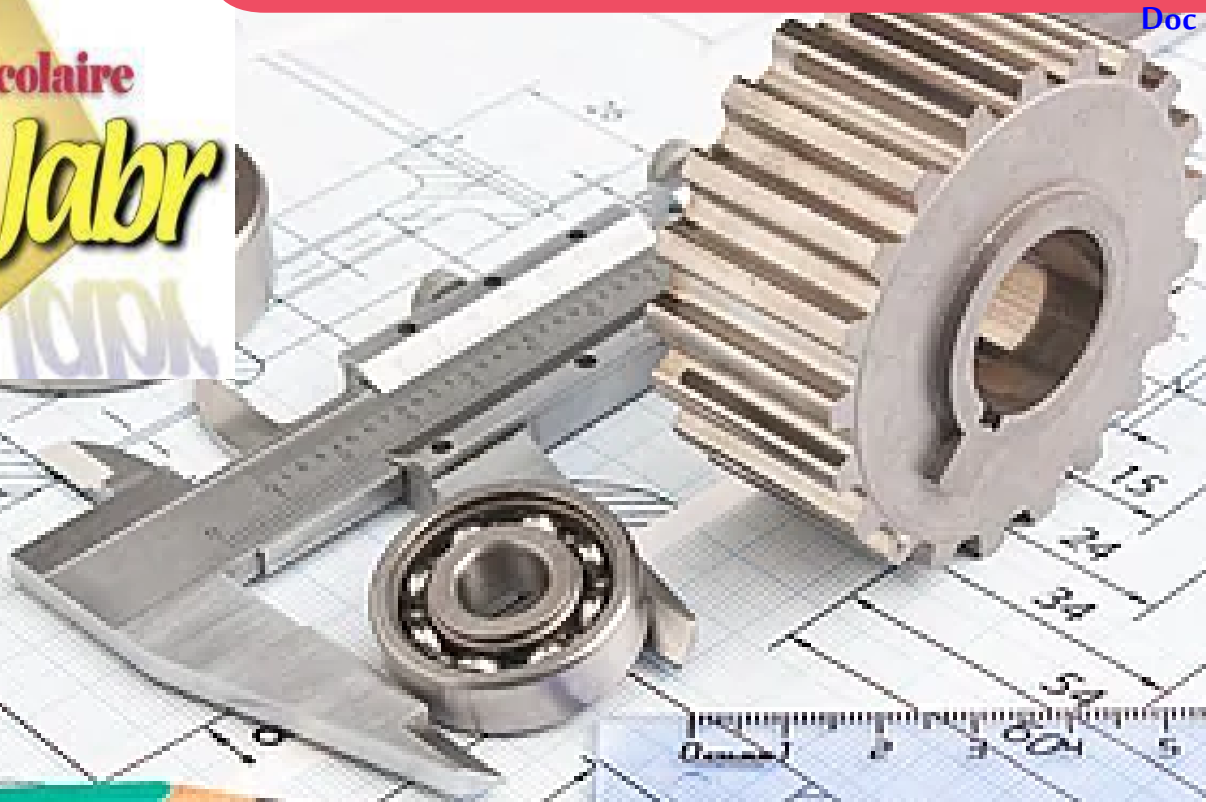

Exercices avec réponse **dessin industriel**

- *projection orthogonale*
- *coupe*
- *section*

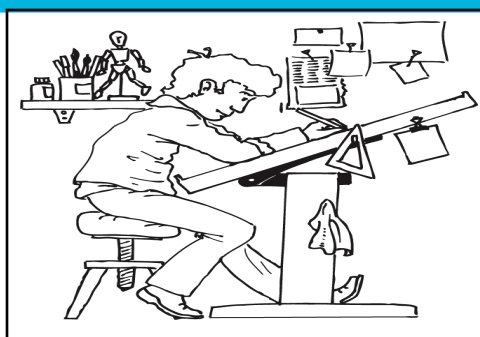

Prof : Lakhil



Compléter les vues suivantes

.TD N: 1

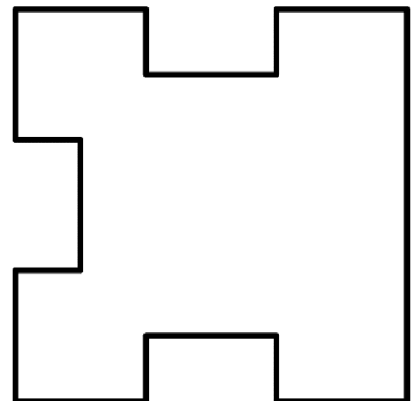
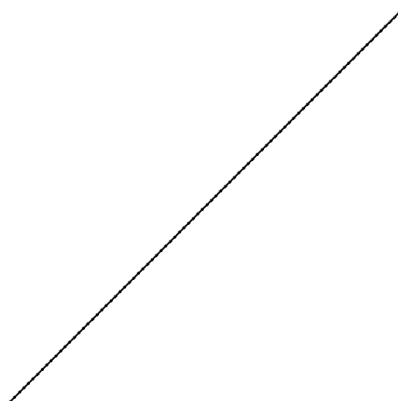
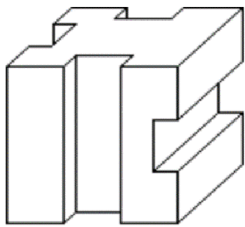
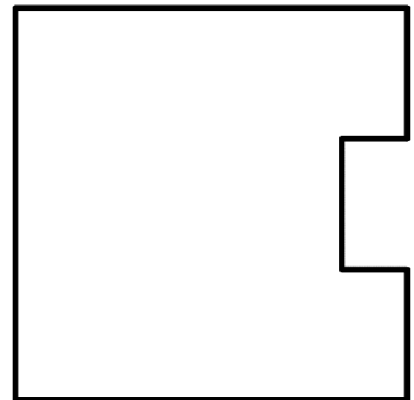
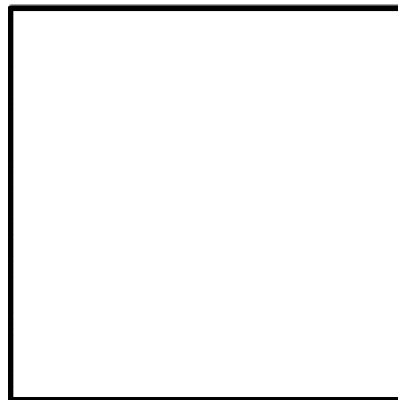

.TD N: 2

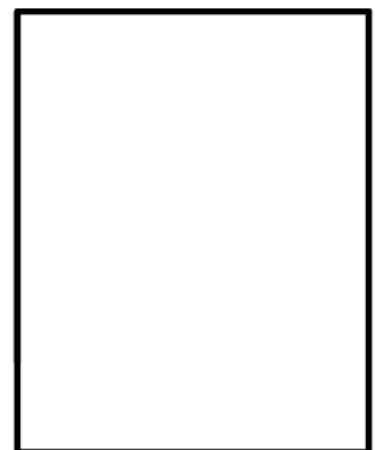
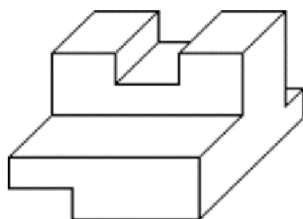
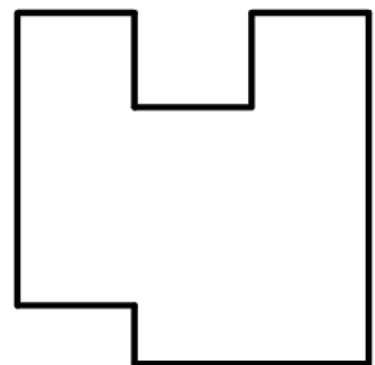
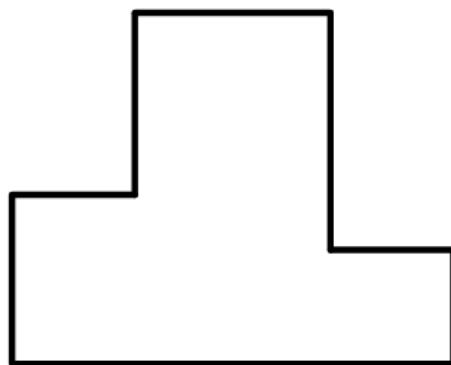

TD N: 3

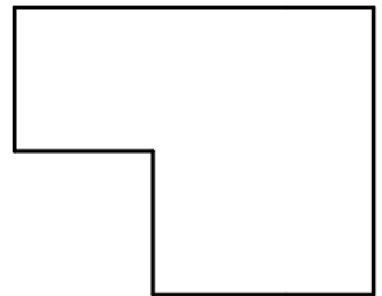
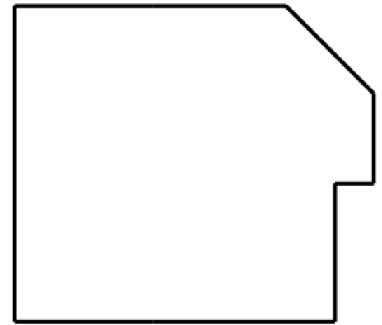
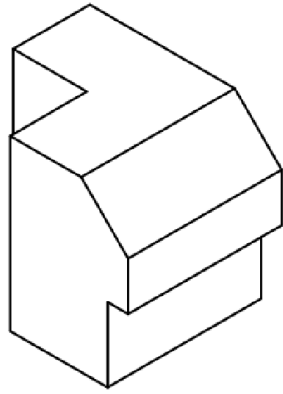

.4) TD N: 4

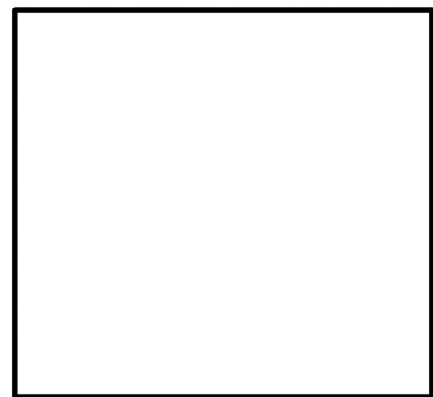
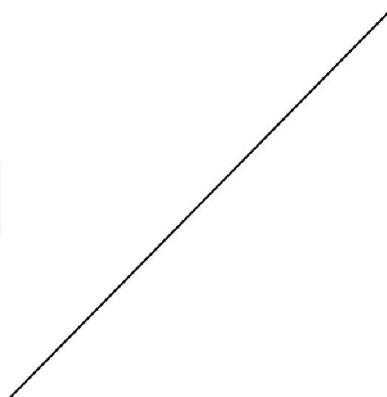
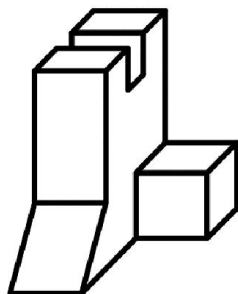
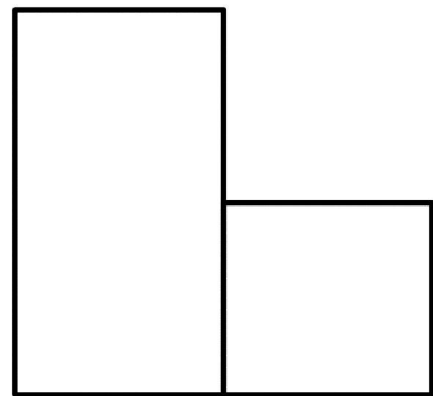
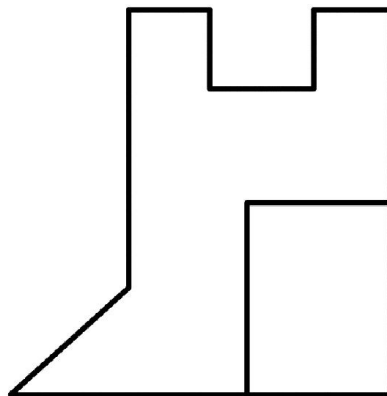

.TD N: 5

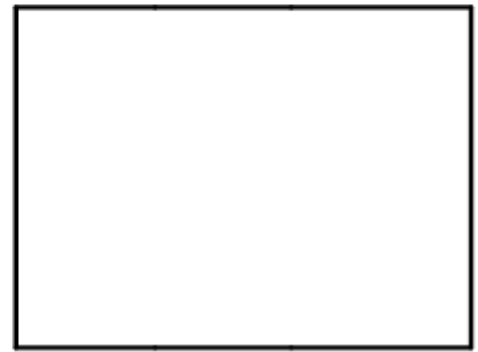
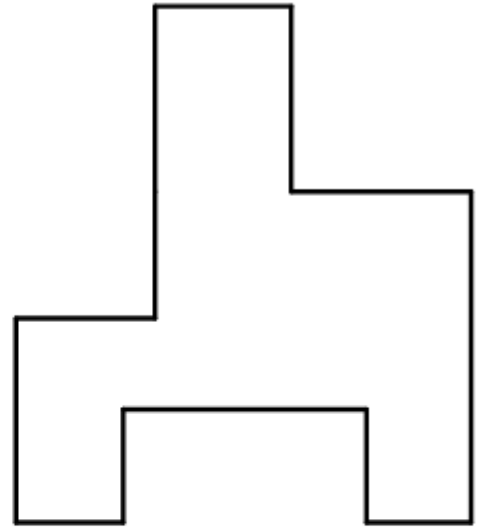
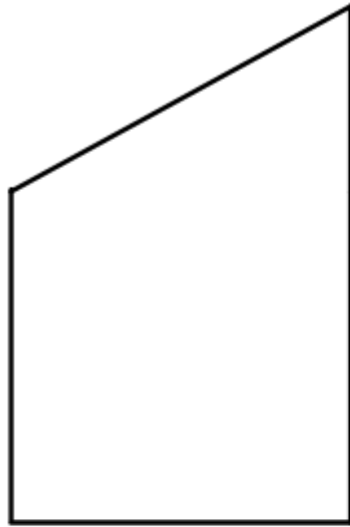
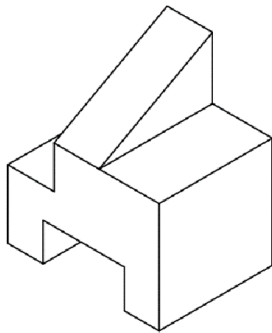

.TD N: 6

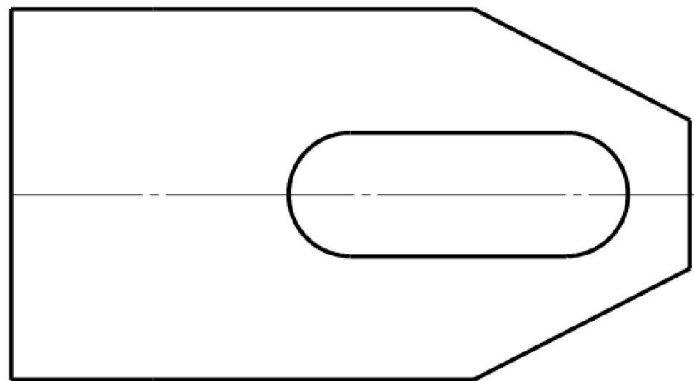
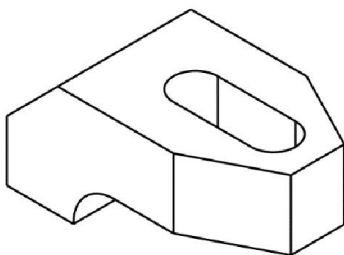
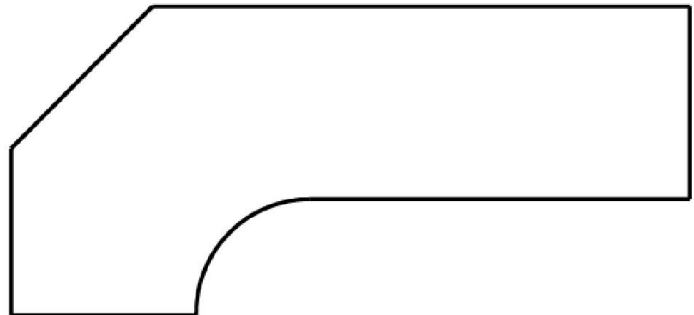
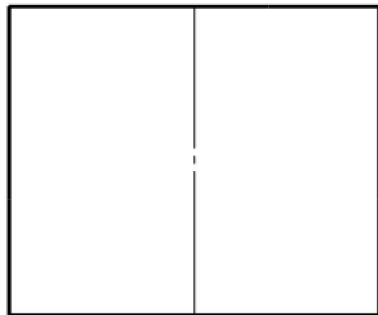

.TD N: 7

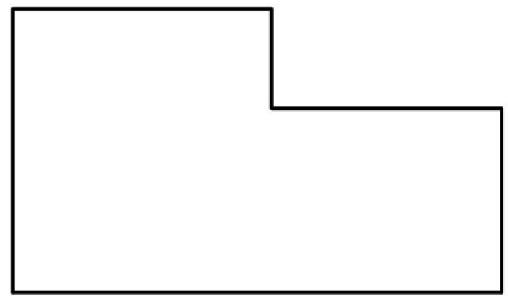
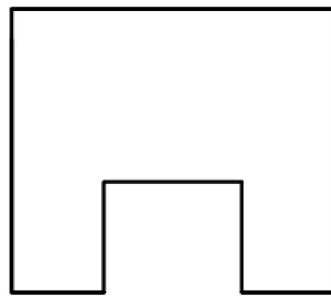
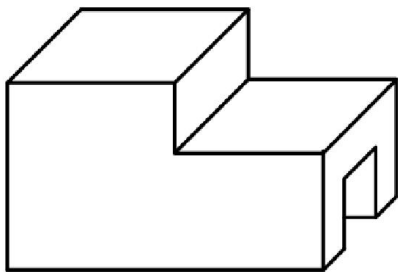

.TD N: 8

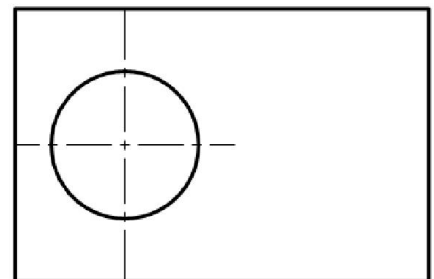
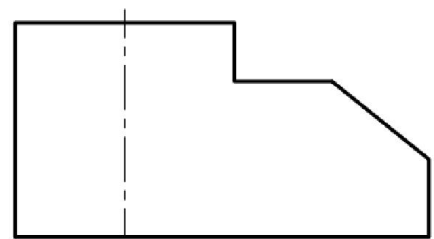
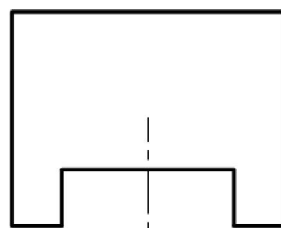
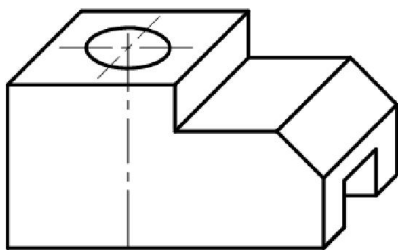

.TD N: 9

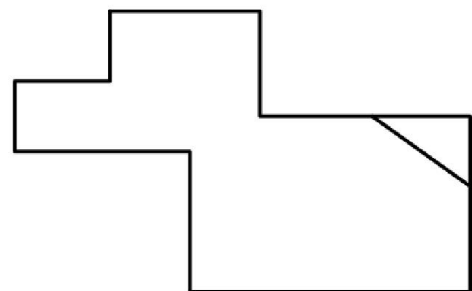
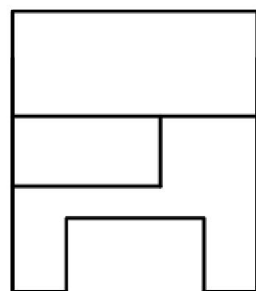
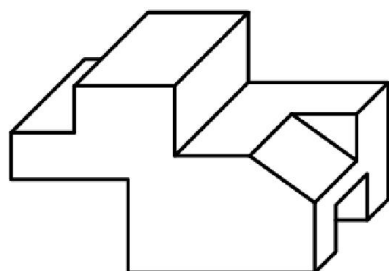

TD N: 10

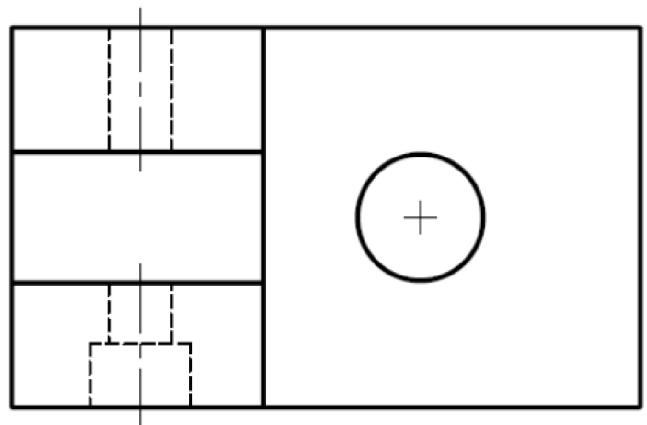
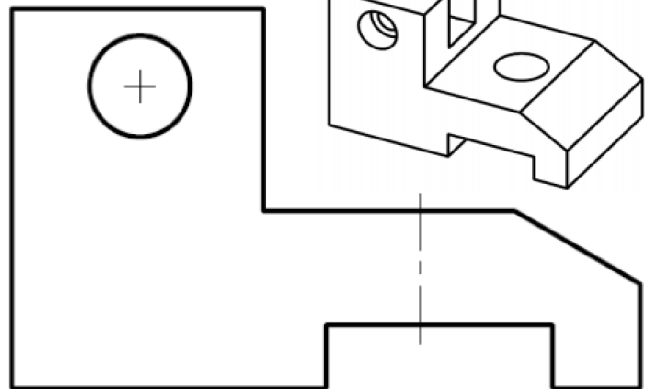
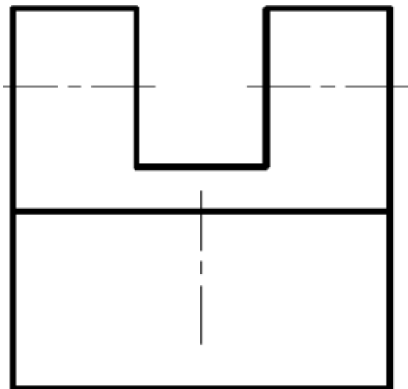

TD N: 11

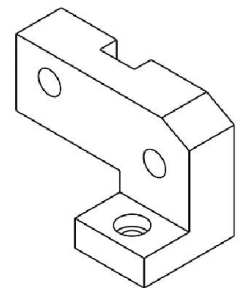
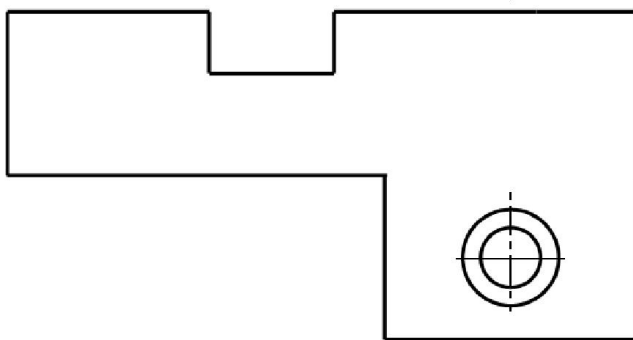
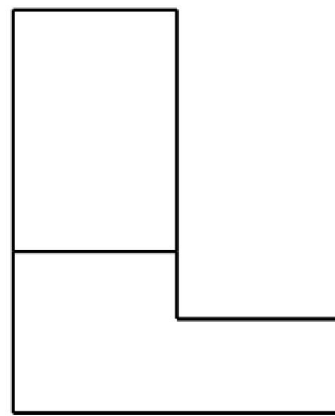
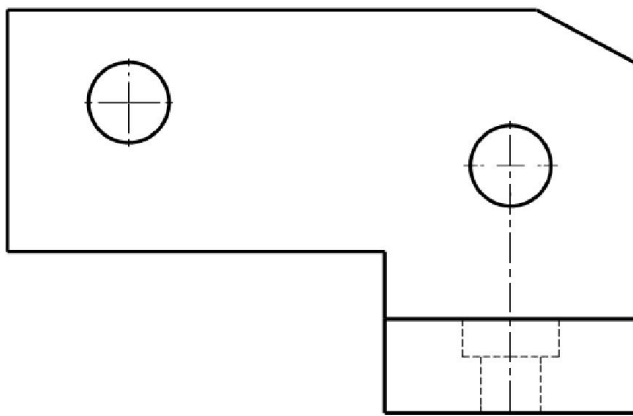

.TD N: 12

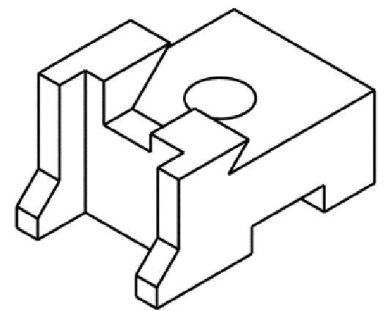
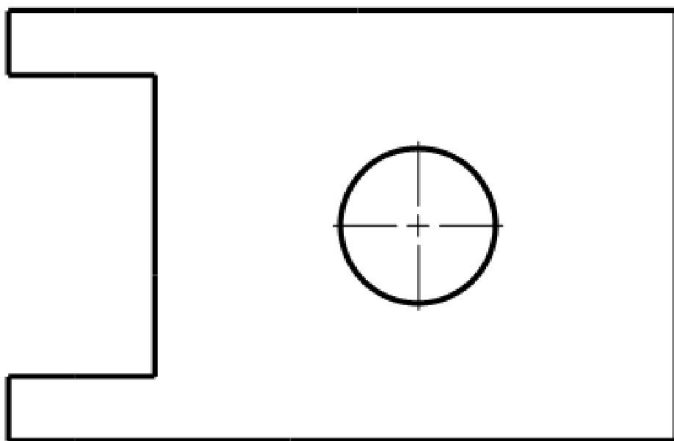
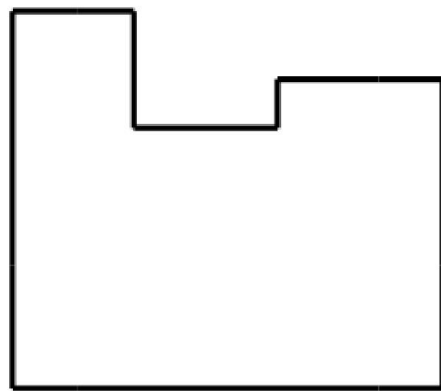
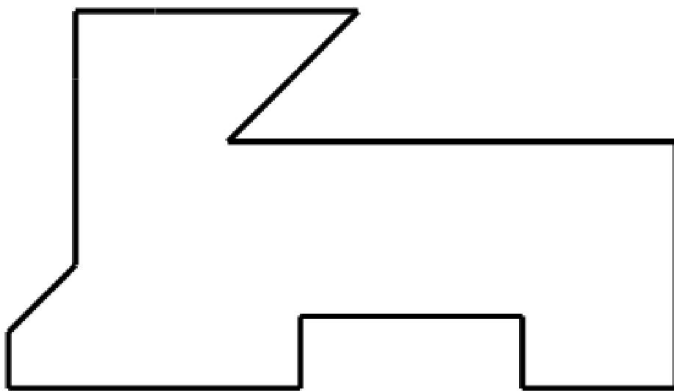

TD N: 13

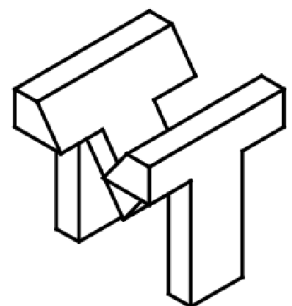
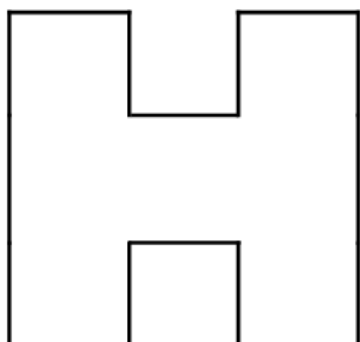
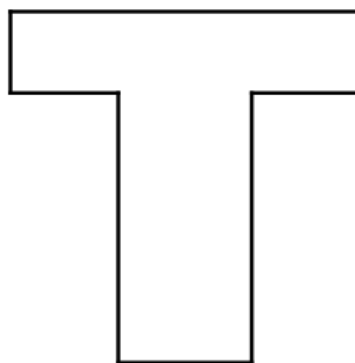
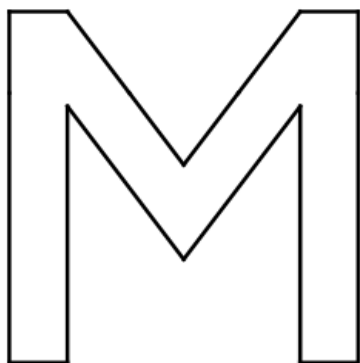

.TD N: 14

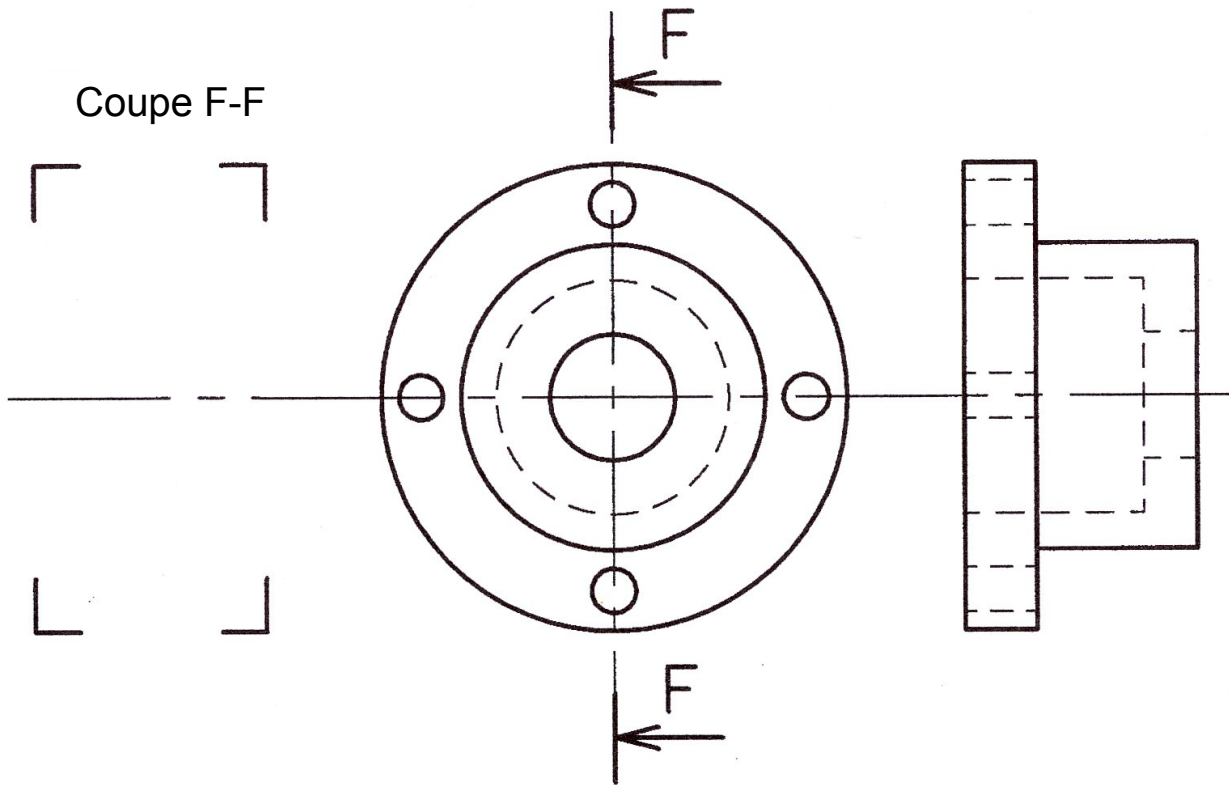
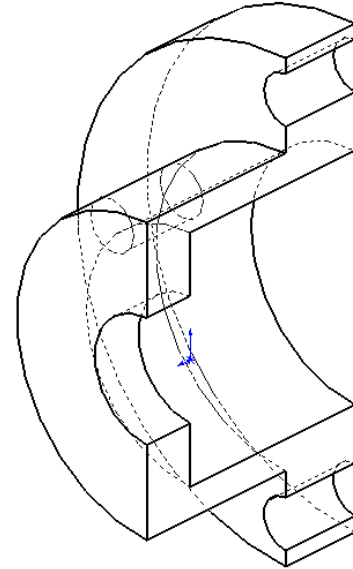
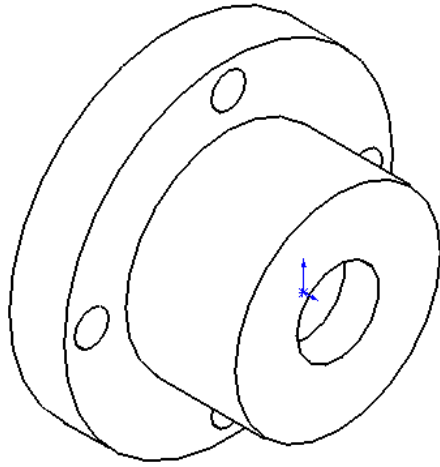

.TD N: 15

Exercices: coupe simple

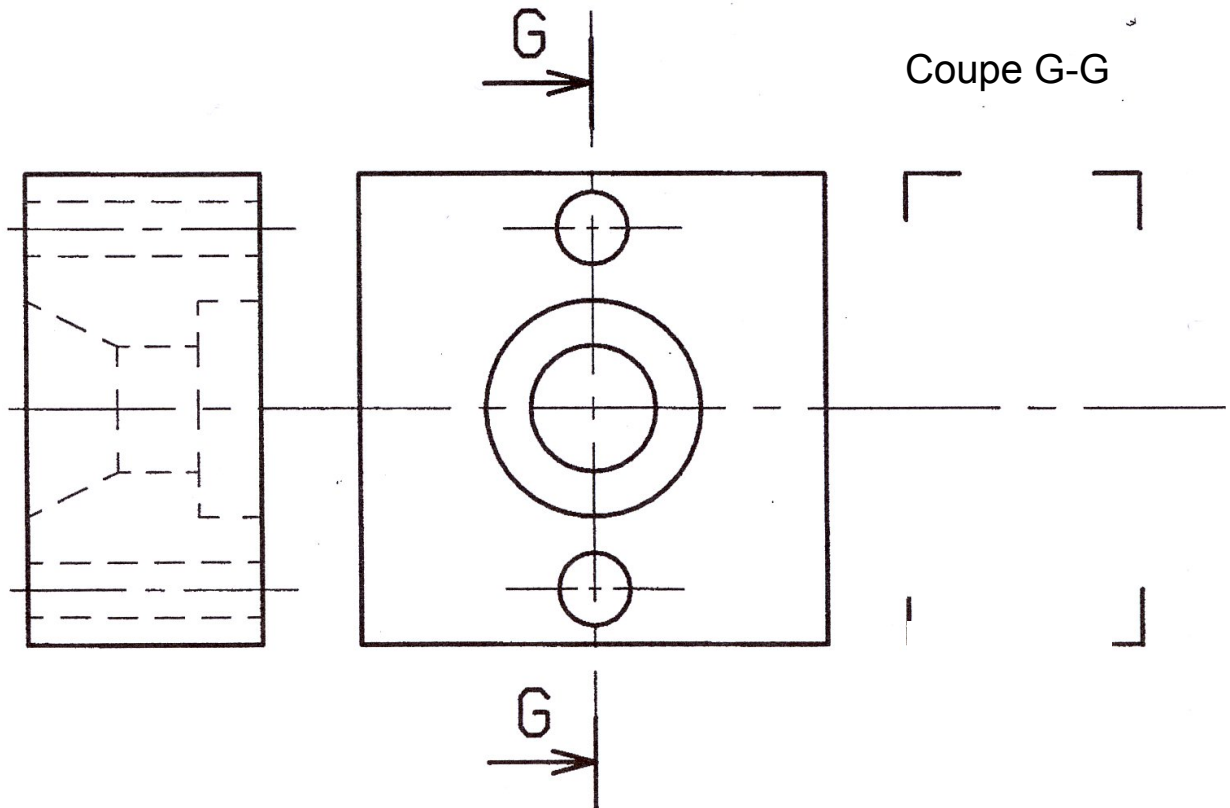
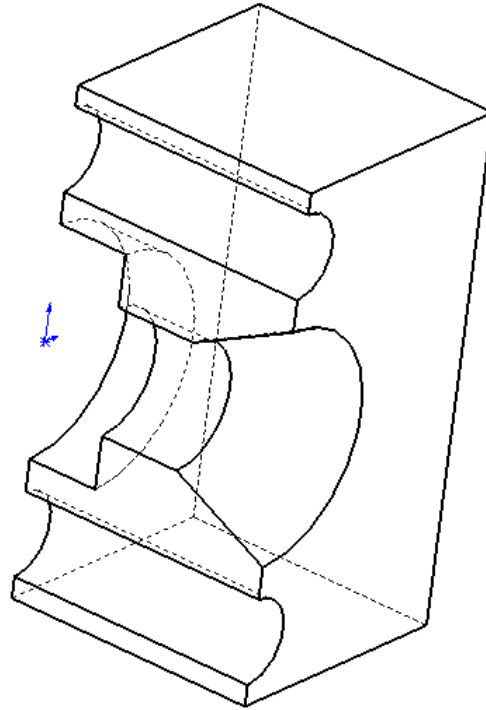
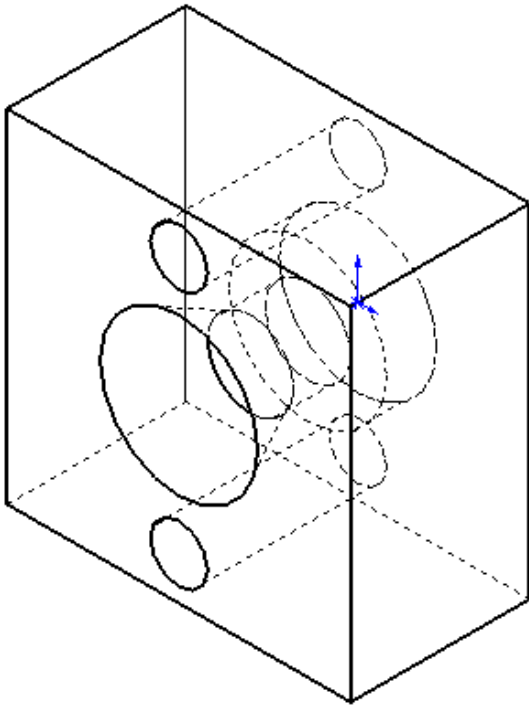

.TD N: 16

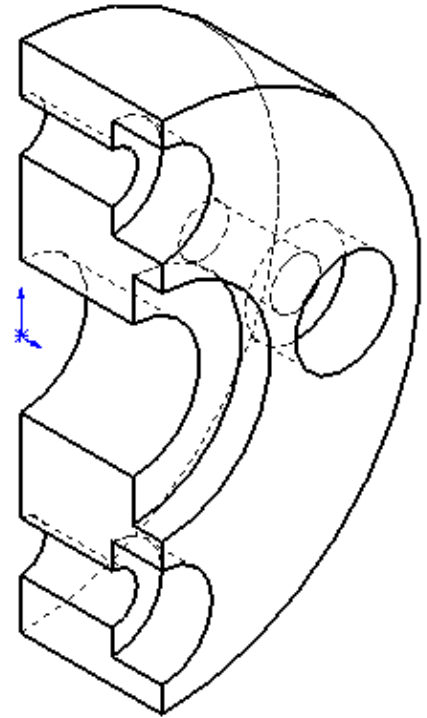
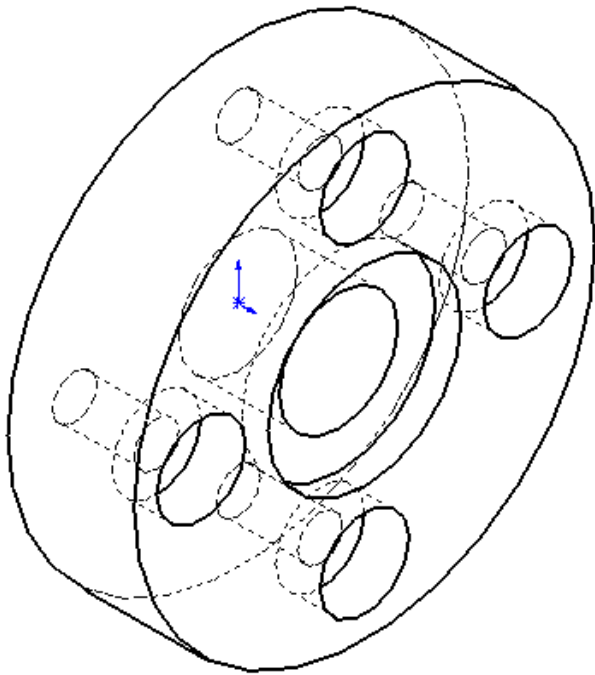

Coupe J-J

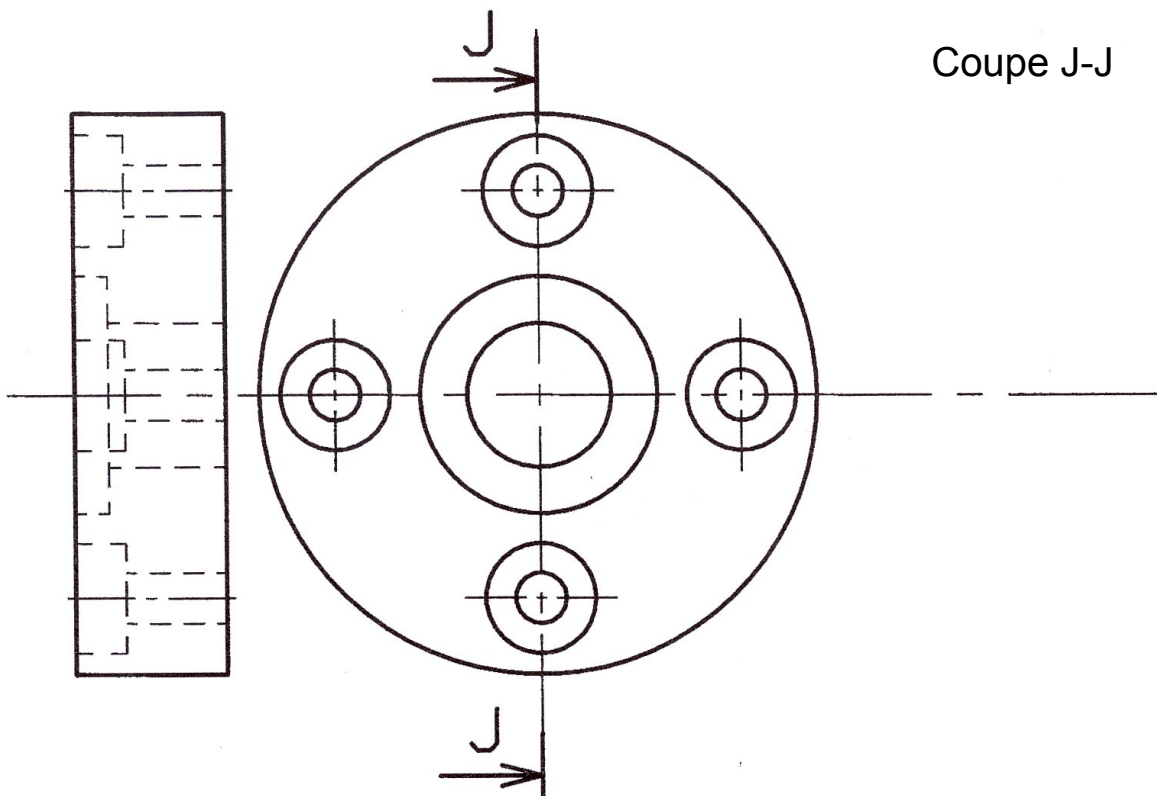

TD N: 17

Compléter la section H-H le de cette piece .

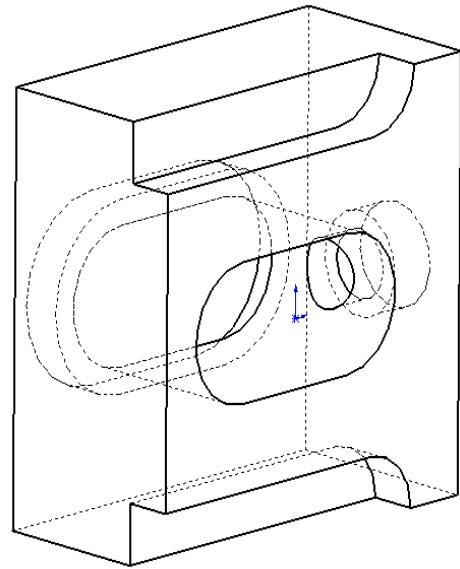

section H-H

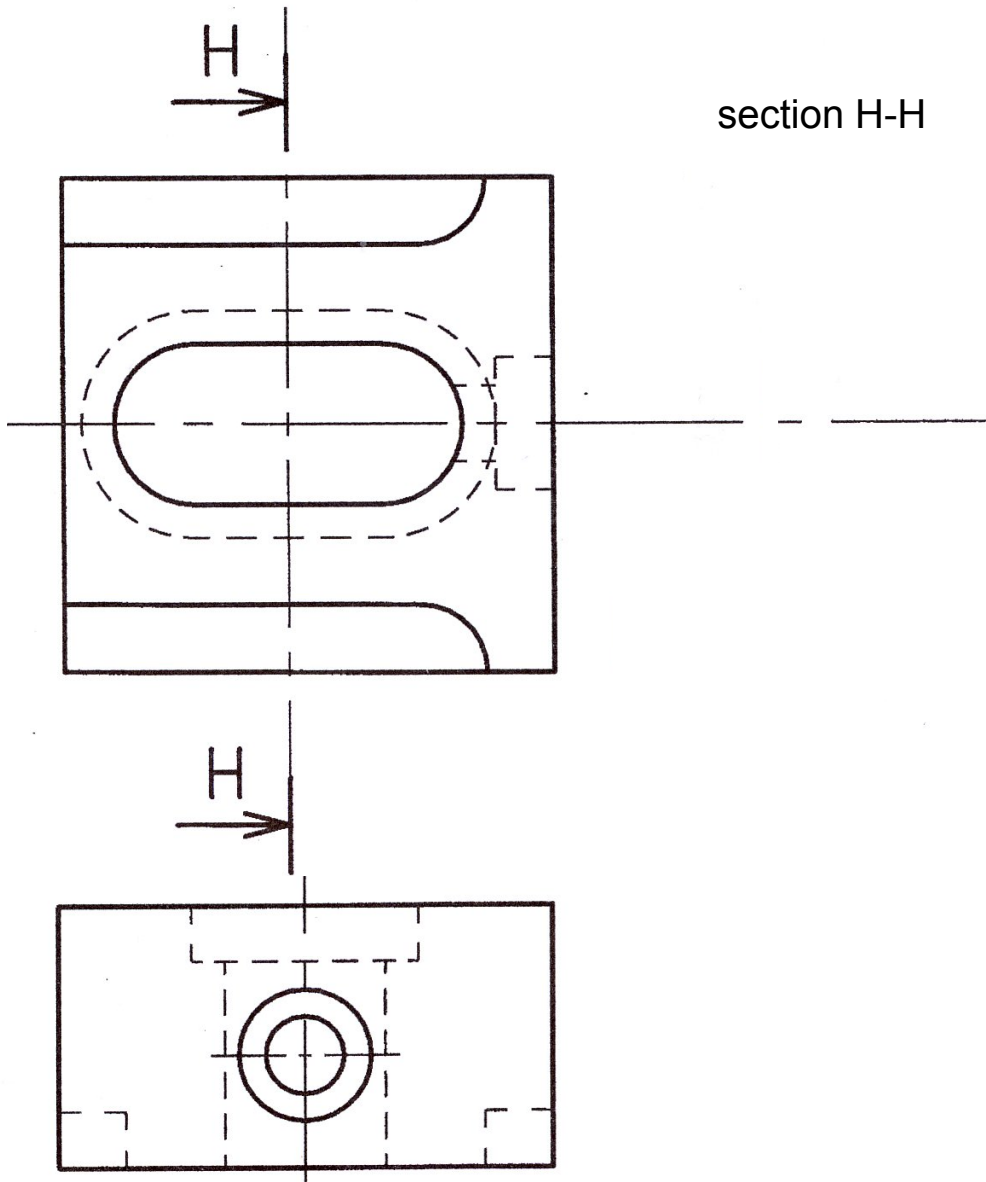

الامتحان الوطني الموحد للبكالوريا
الدورة العادية 2021

.TD N: 18

- Compléter le dessin de la chape en :
 - Vue de droite en coupe B-B (Ne pas représenter les formes cachées).
 - Vue de dessus en coupe A-A (Représenter les formes cachées).

/2,25

Vue 3D de la chape

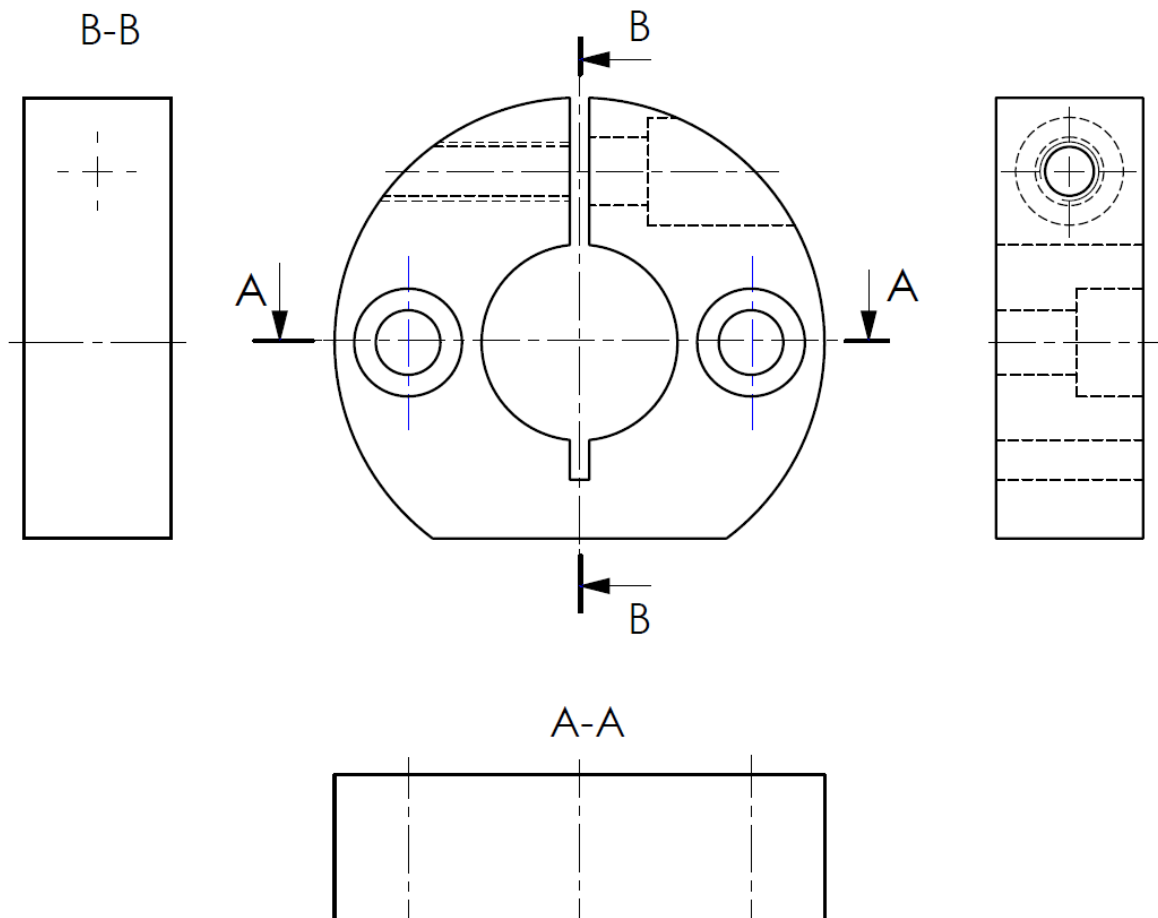
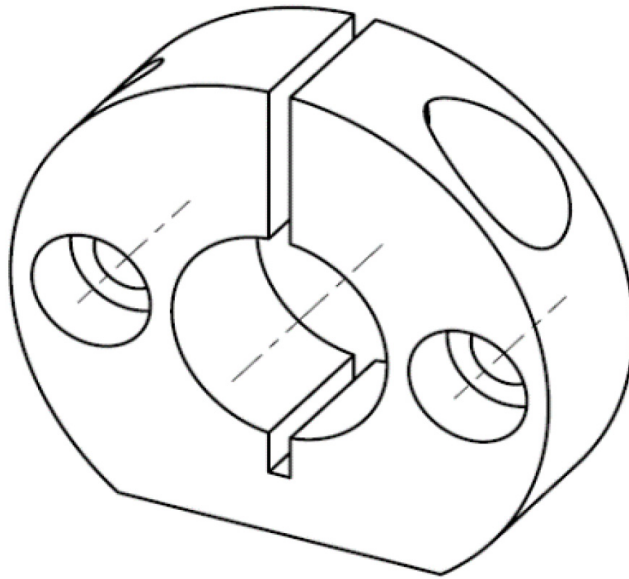

الامتحان الوطني الموحد للبكالوريا
الدورة الاستدراكية 2021

.TD N: 19

- Représenter la pièce (11) en vue de face coupe A-A en respectant la cotation.

2,00 pts

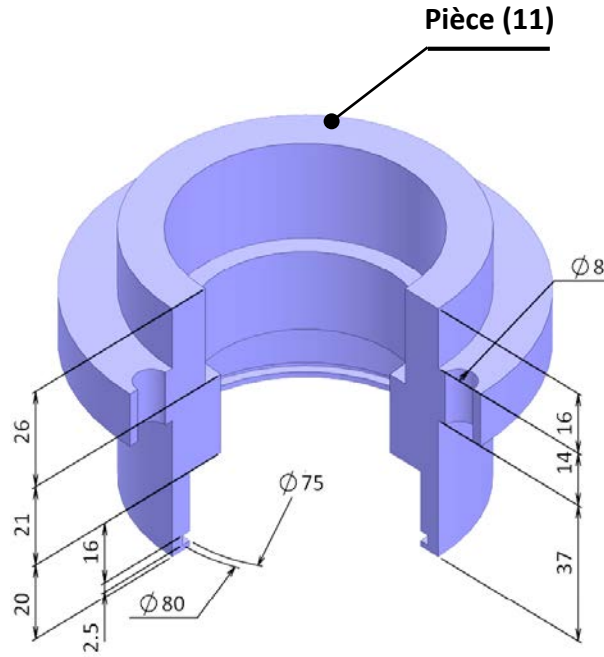

2,00 pts

A-A

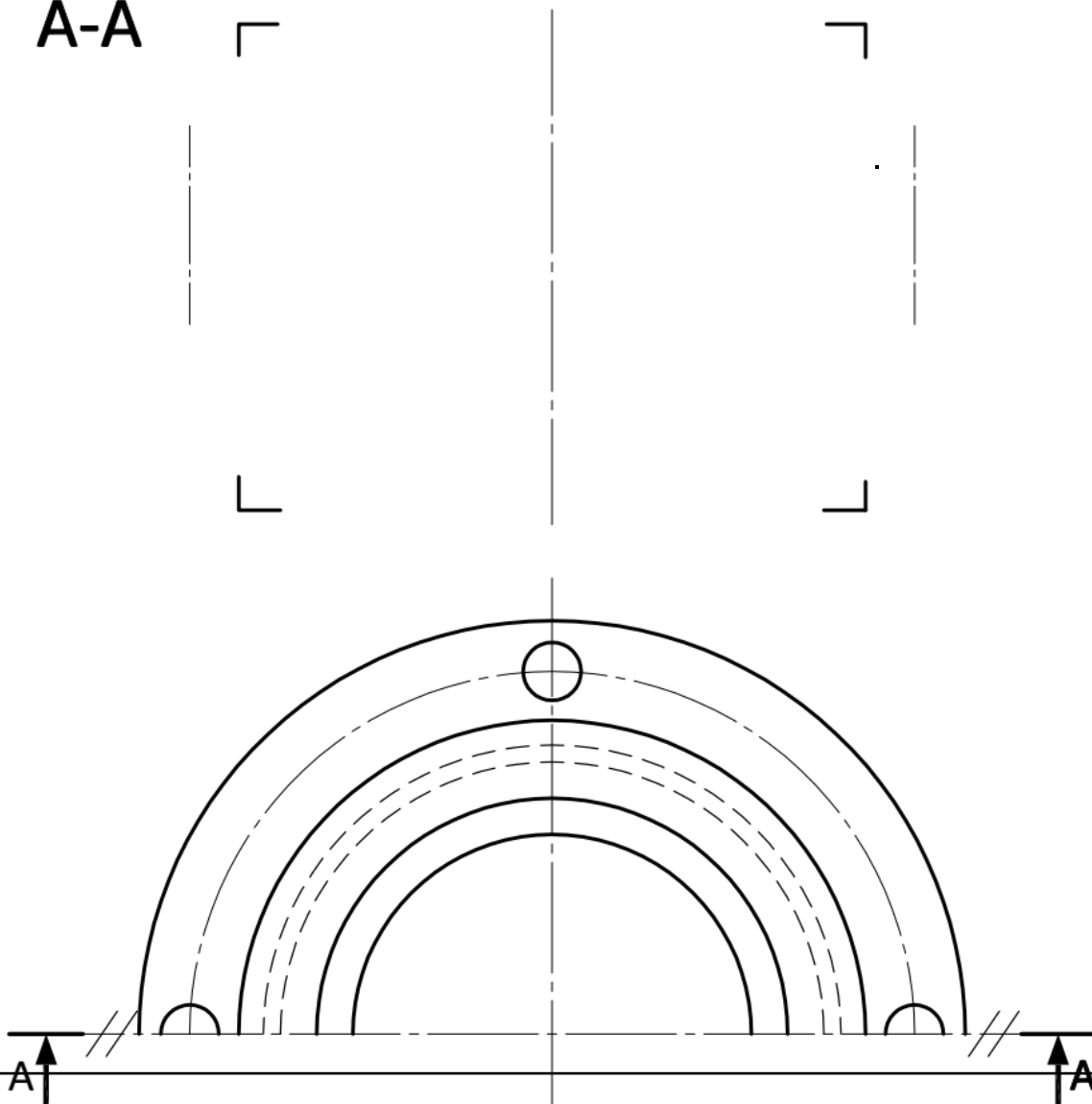

الامتحان الوطني الموحد للبكالوريا

الدورة العادية 2020

TD N: 20

Compléter les vues suivantes du dessin de la chappe montée sur la tige du vérin :

(Représenter toutes les formes cachées)

- La vue de gauche en coupe A-A.
- La vue de dessus.

Dessin 3D de la Chappe montée sur la tige du vérin

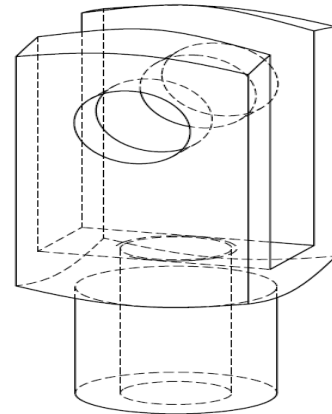

A-A

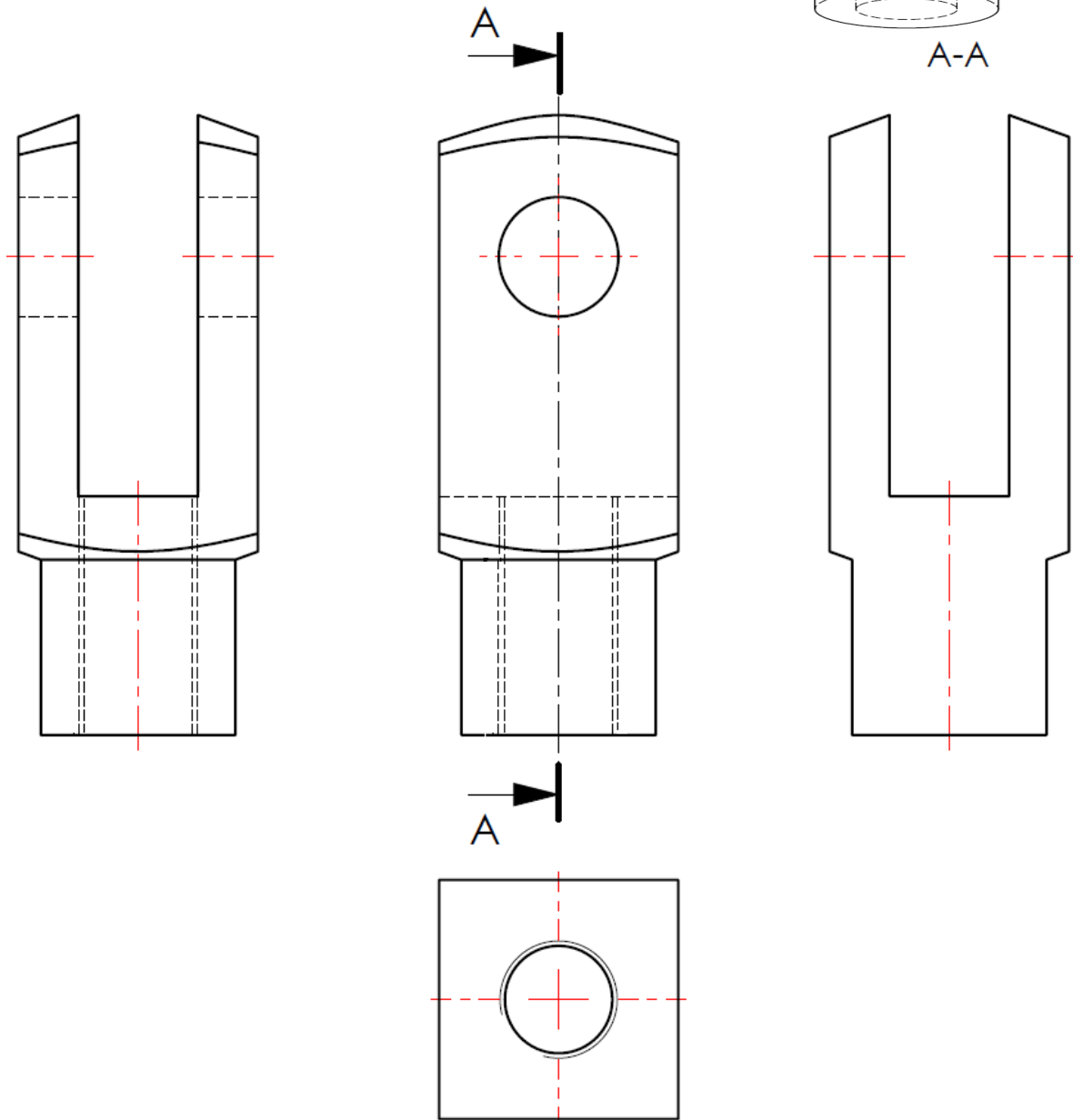

/2,25

TD N: 21

الامتحان الوطني الموحد للبكالوريا الدورة الاستدراكية 2020

Q. Compléter le dessin de la **bride** solidaire de l'arbre du **vérin rotatif** en vue de gauche coupe A-A.
(Sans traits cachés)

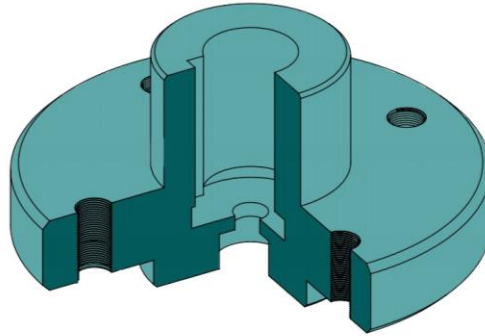

/2,50

Vue en perspective de la bride

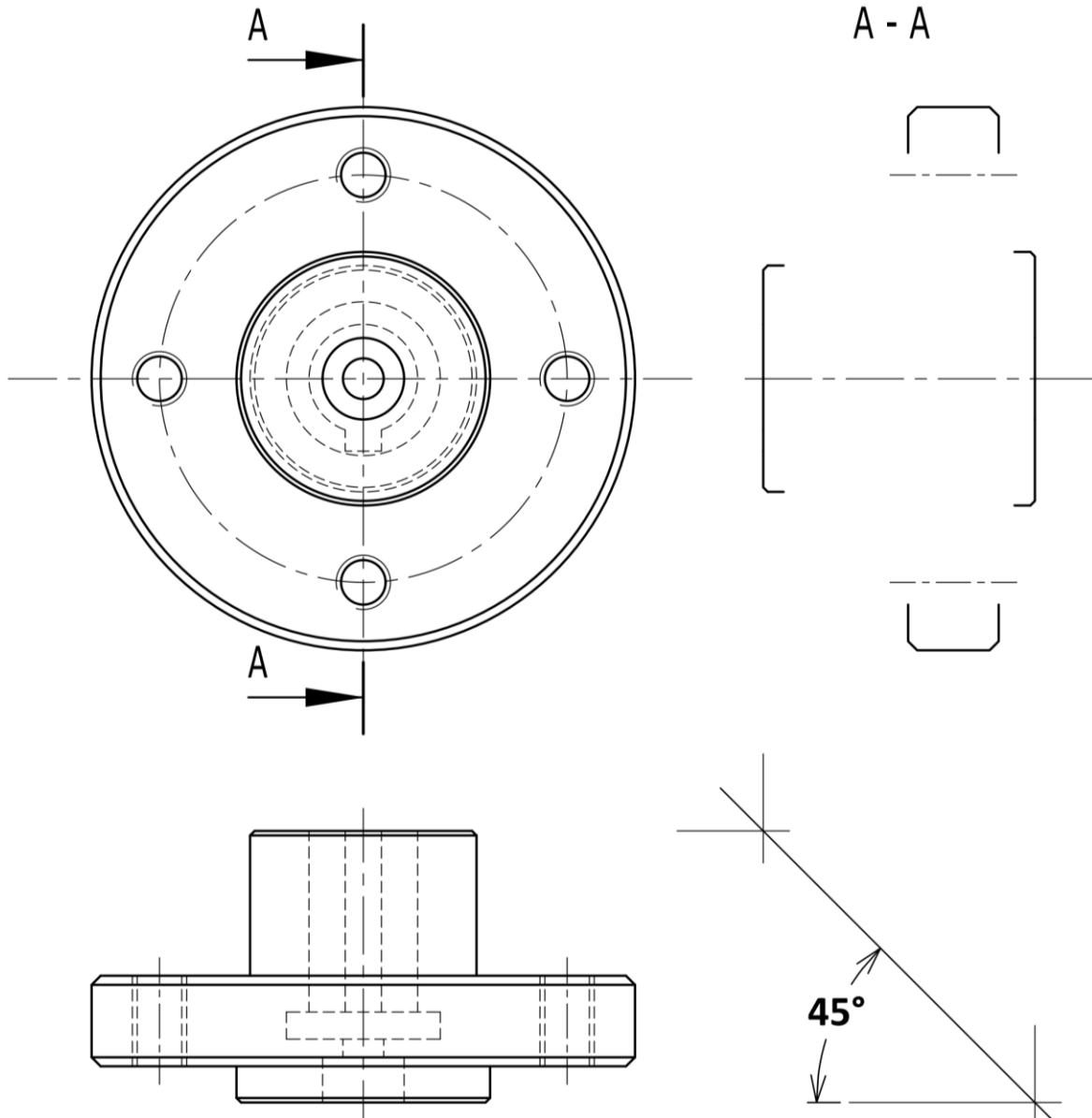

الامتحان الوطني الموحد للبكالوريا
الدورة العادية 2019

TD N: 22

Compléter la vue de face en coupe A-A du dessin du support de rail lamé.

Vue en 3D du support de rail lamé seul

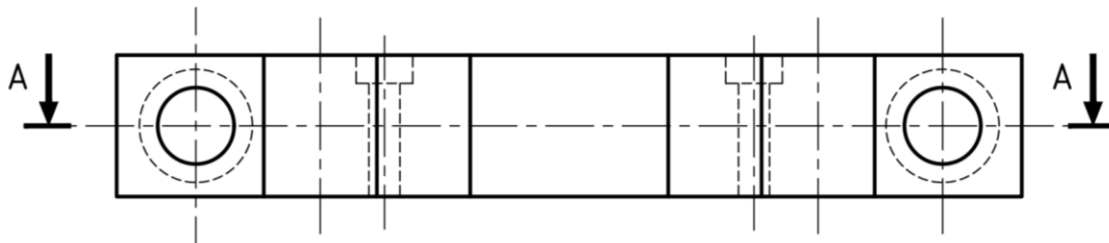
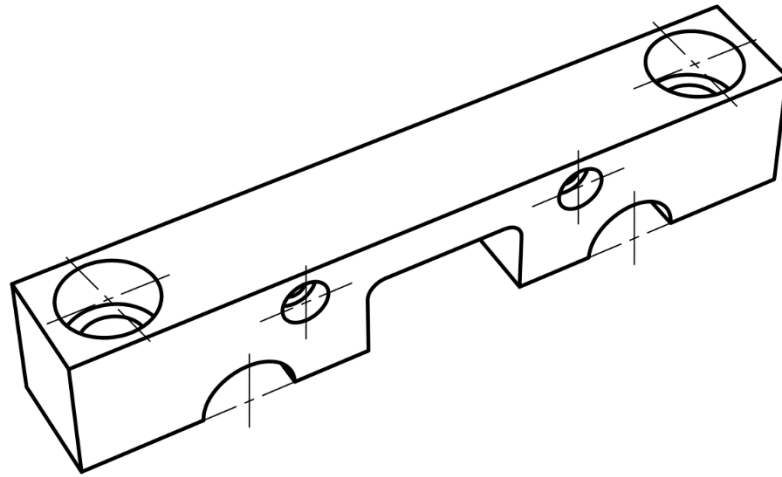

A - A

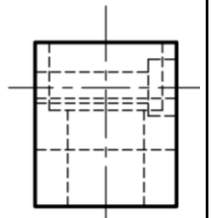
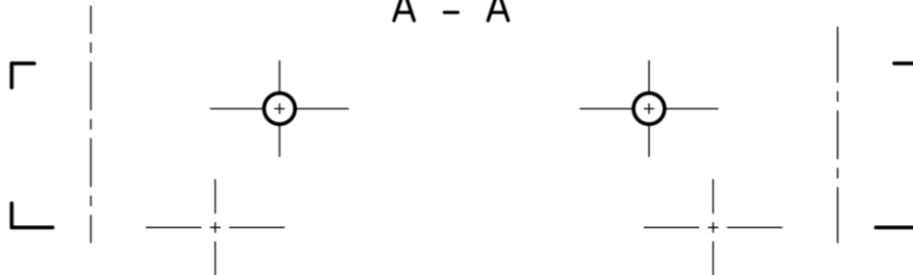

الامتحان الوطني الموحد للبكالوريا

TD N: 23

الدورة الاستدراكية 2019

Compléter la vue de gauche en coupe A-A de cet accouplement sans représenter les arêtes cachées. 2,00 pts

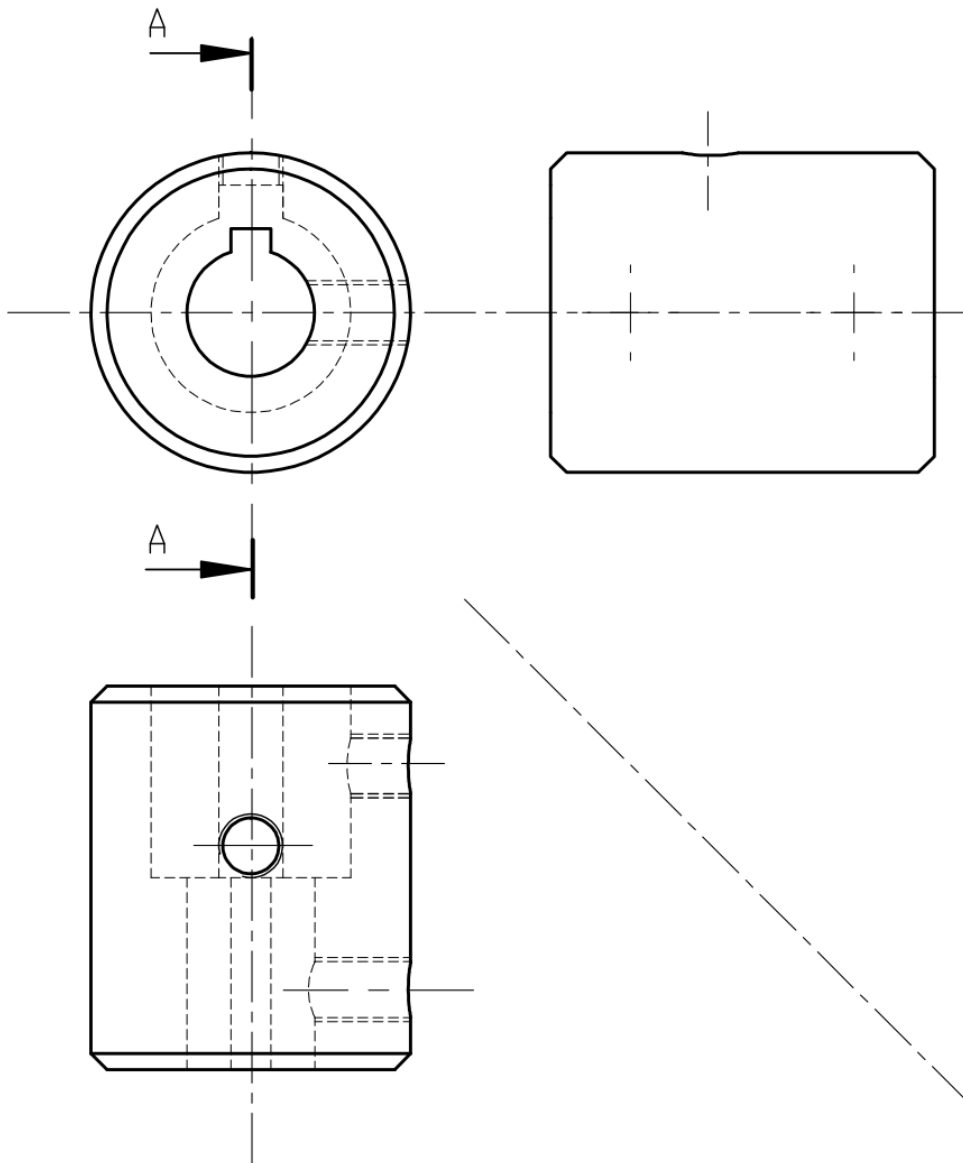
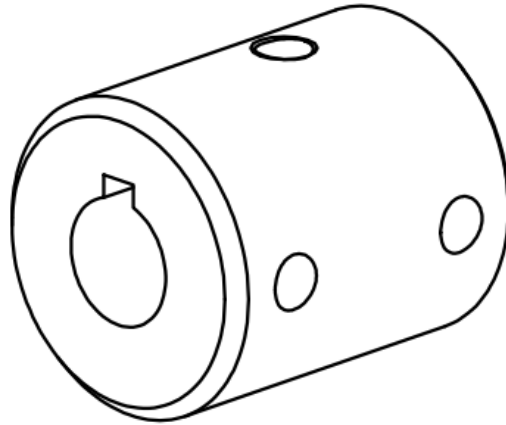
Représentation 3D du manchon de l'accouplement

الامتحان الوطني الموحد للبكالوريا

TD N: 24

الدورة العادية 2022

Q. Compléter le dessin de la buse en :

2,50 pts

- Vue de face en coupe A-A.
- Vue de droite.

Nota : Voir le rendu 3D de la buse en 1/4 enlevé

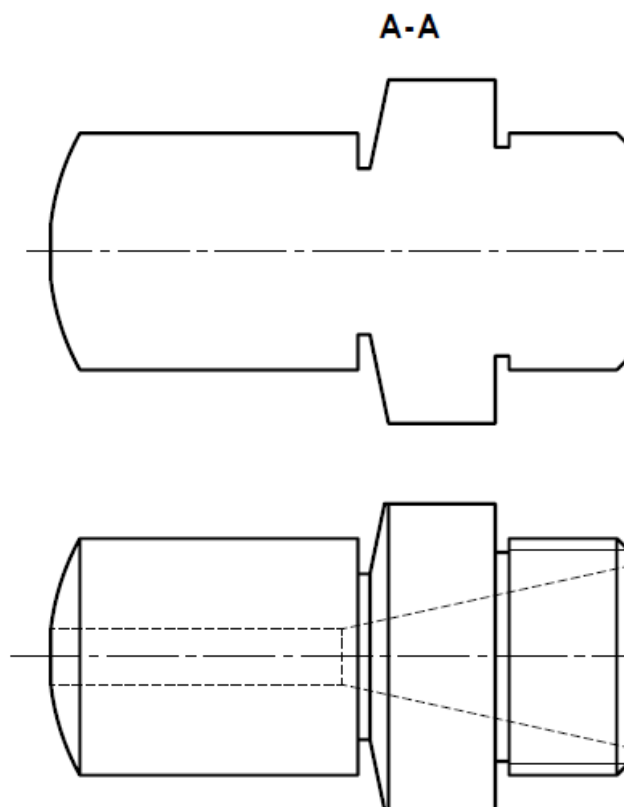
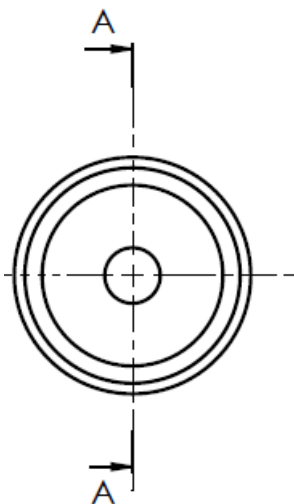
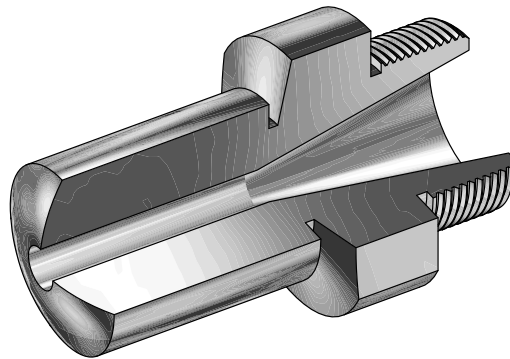

الامتحان الوطني الموحد للبكالوريا

TD N: 25

الدورة الاستدراكية 2022

Q. Compléter la pièce (3) en vue de :

- Face coupe A-A ;
- droite.

2,00 pts

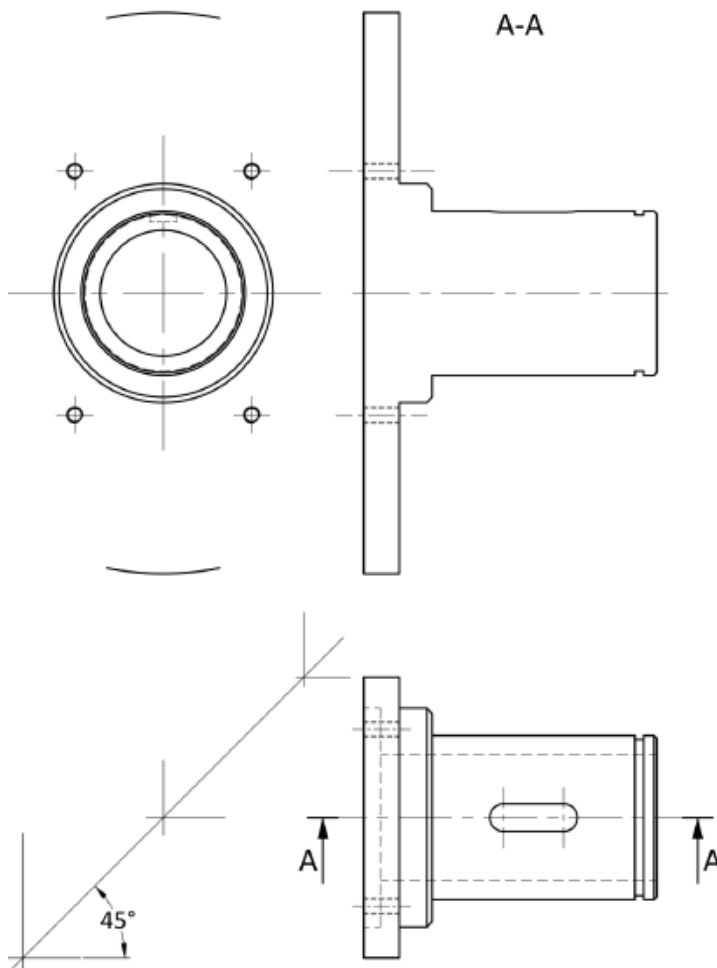
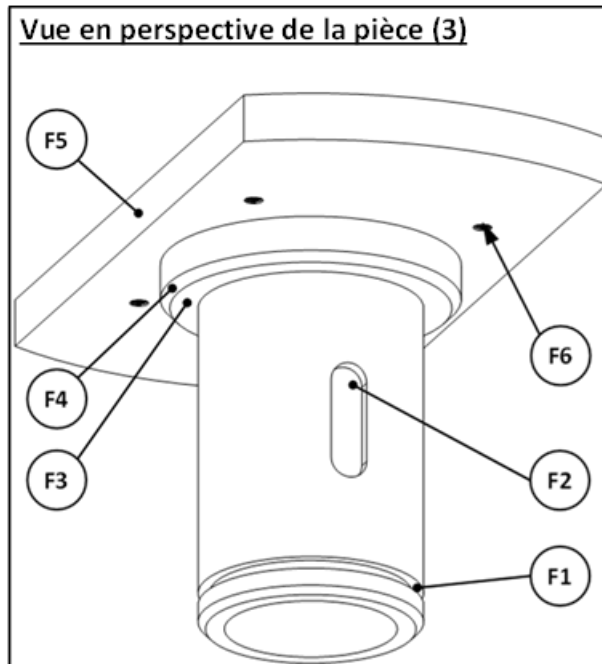



Applications proection orthogonale

علوم المهندس
العلوم الرياضيتا (ب)

Compléter les vues suivantes

.1) TD N:1

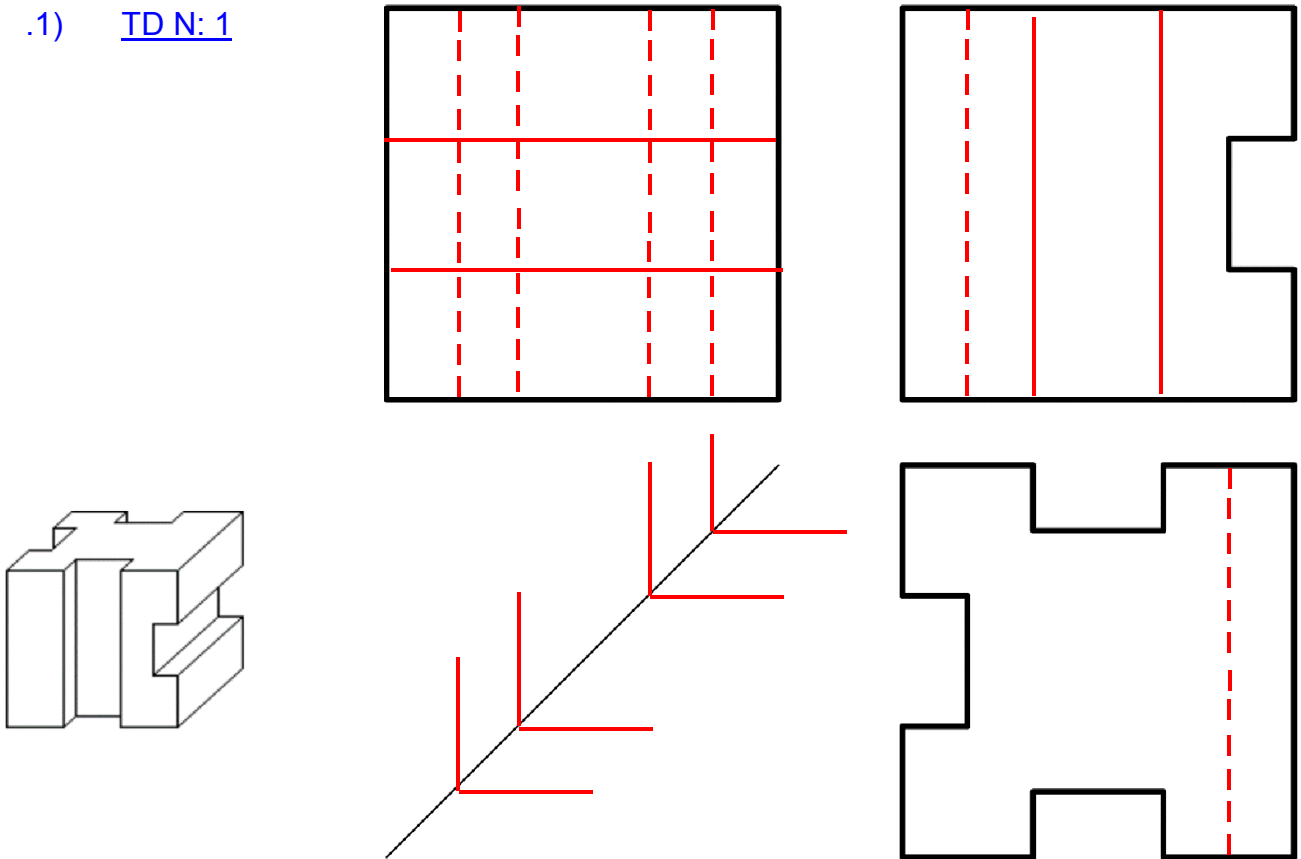

.2) TD N:2

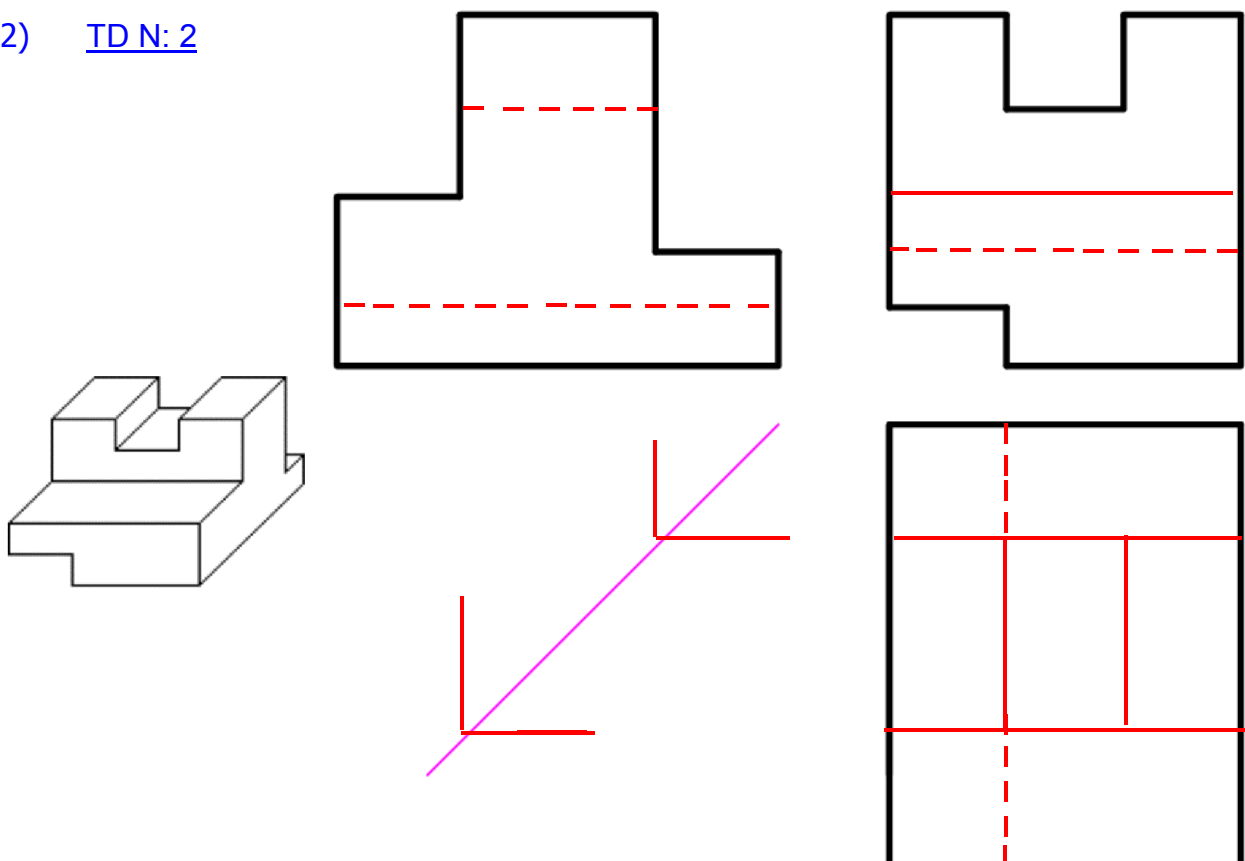

.3) TD N: 3

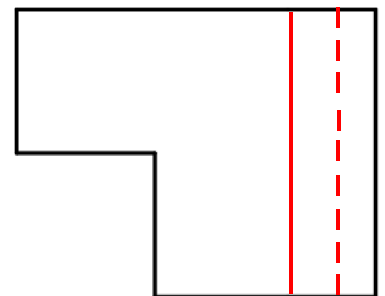
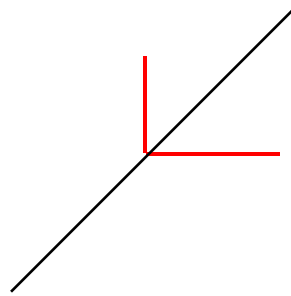
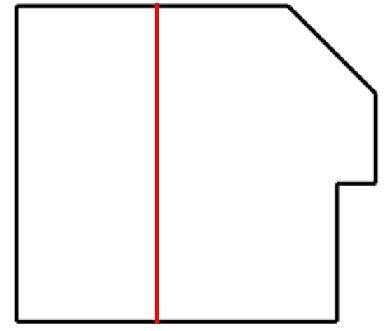
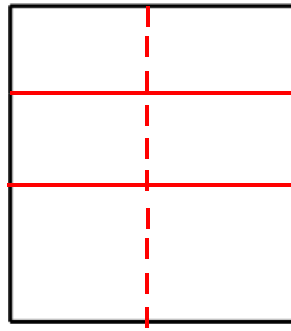
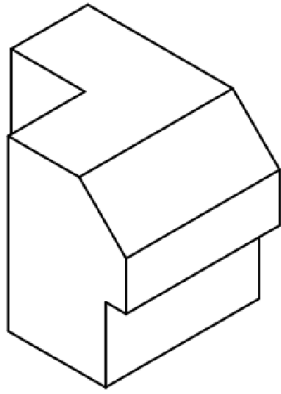

.4) TD N: 4

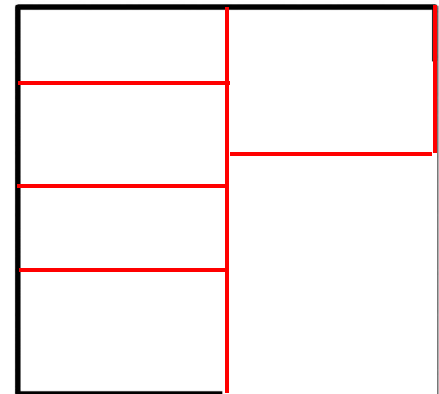
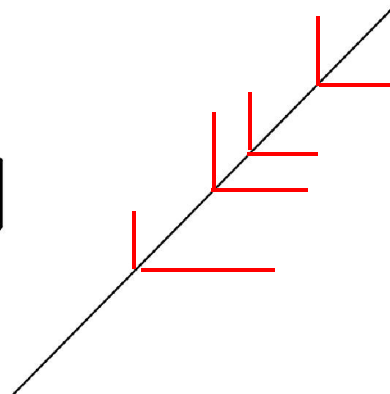
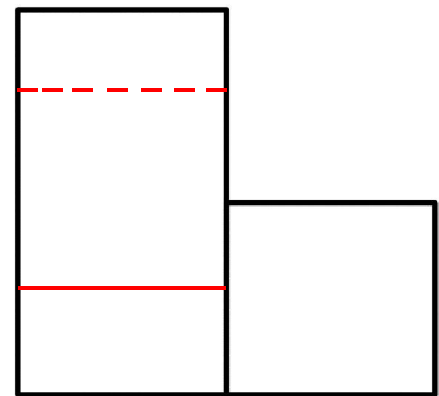
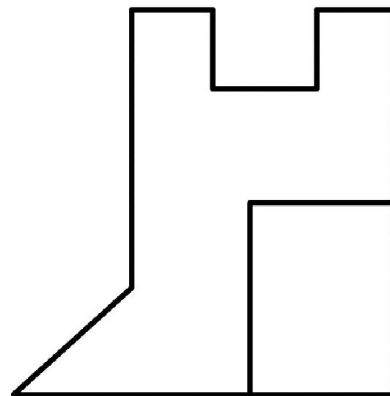
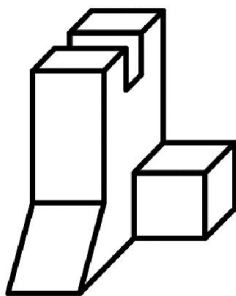

.5) [TD N: 5](#)

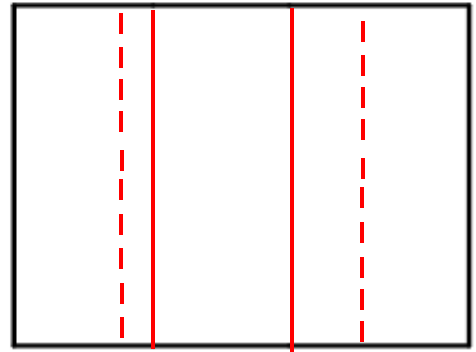
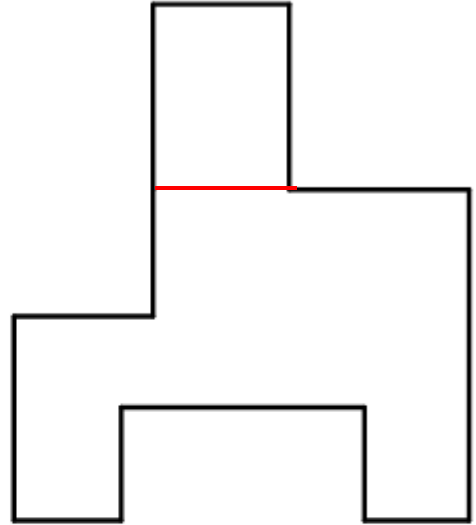
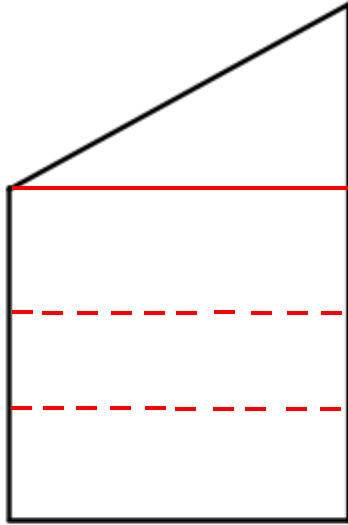
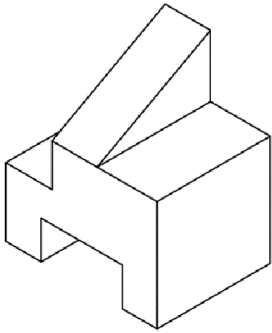

.6) [TD N: 6](#)

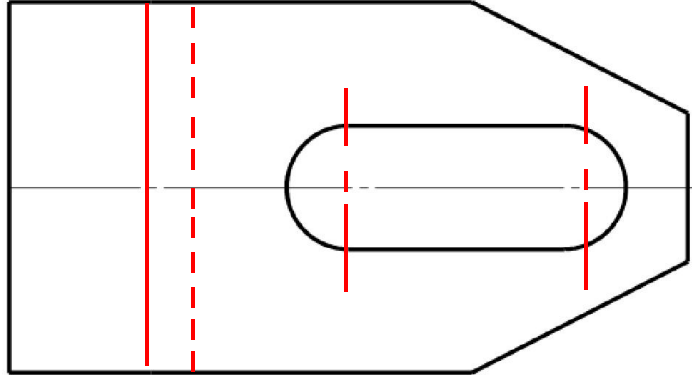
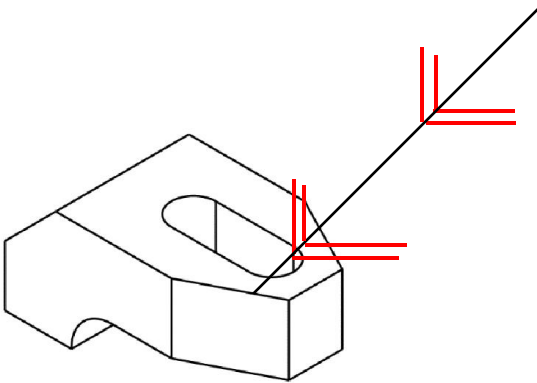
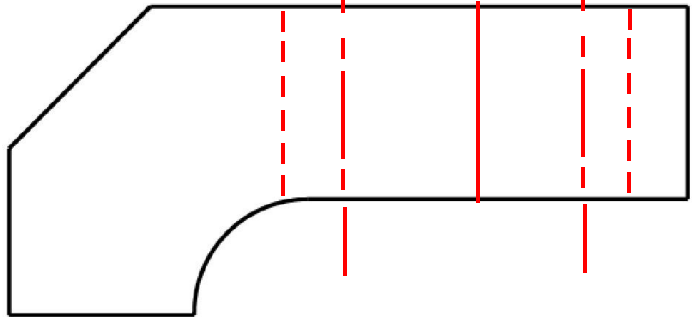
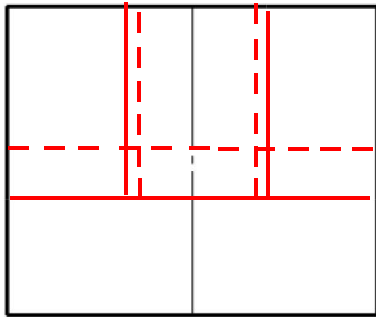

.7) [TD N: 7](#)

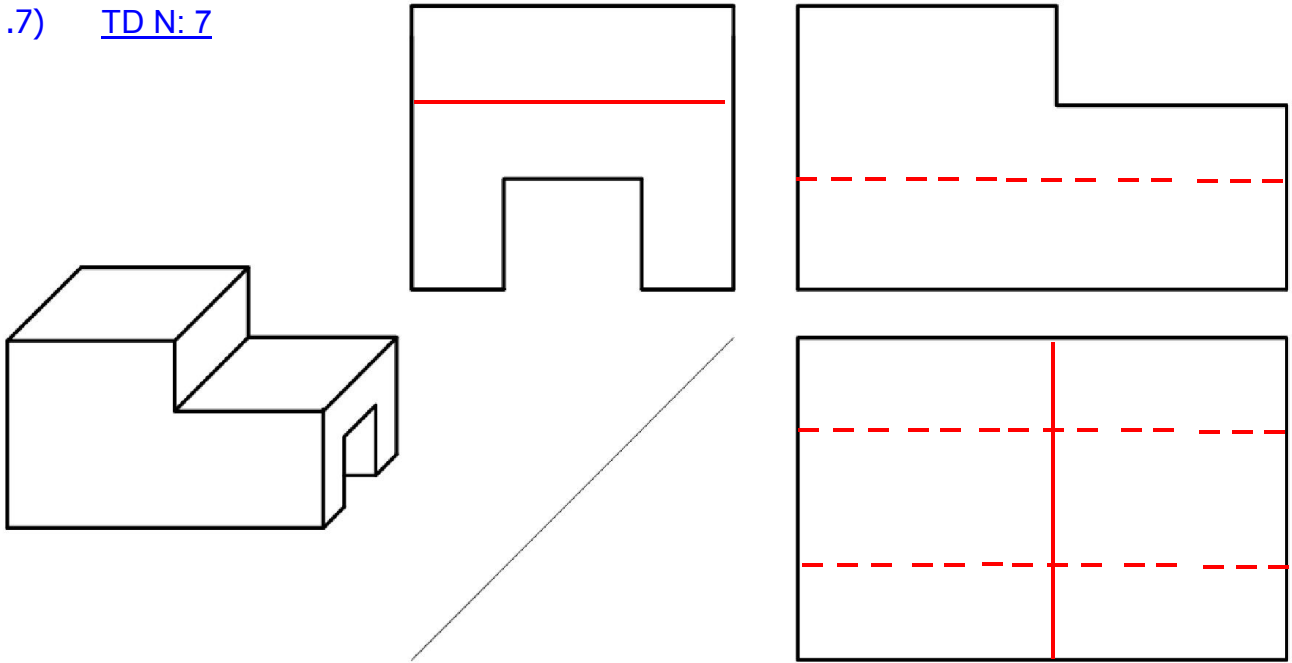

.8) [TD N: 8](#)

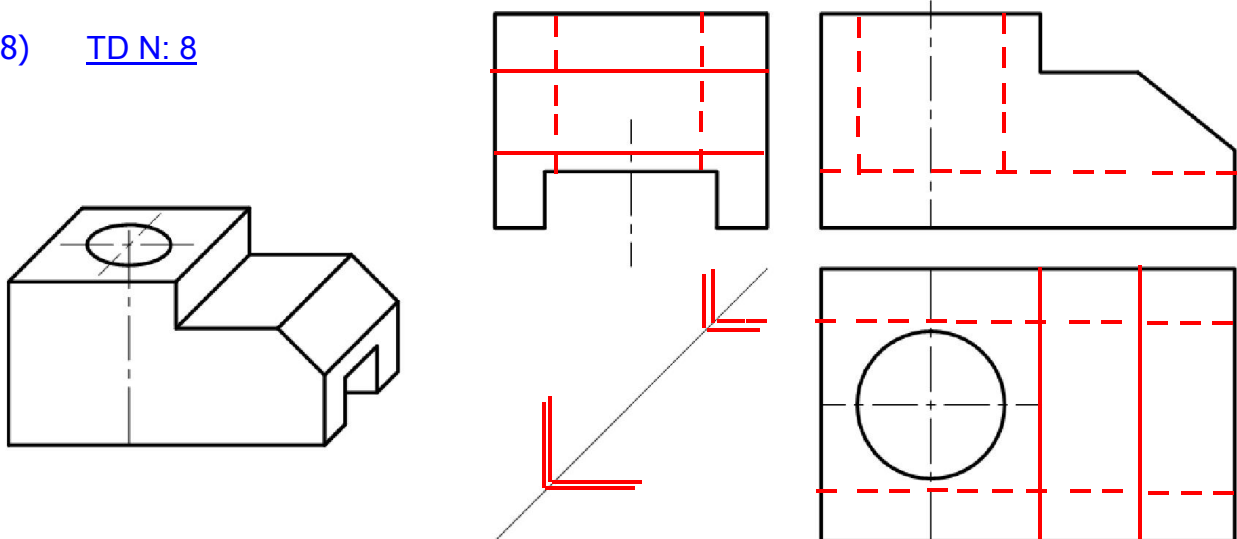

.9) [TD N: 9](#)

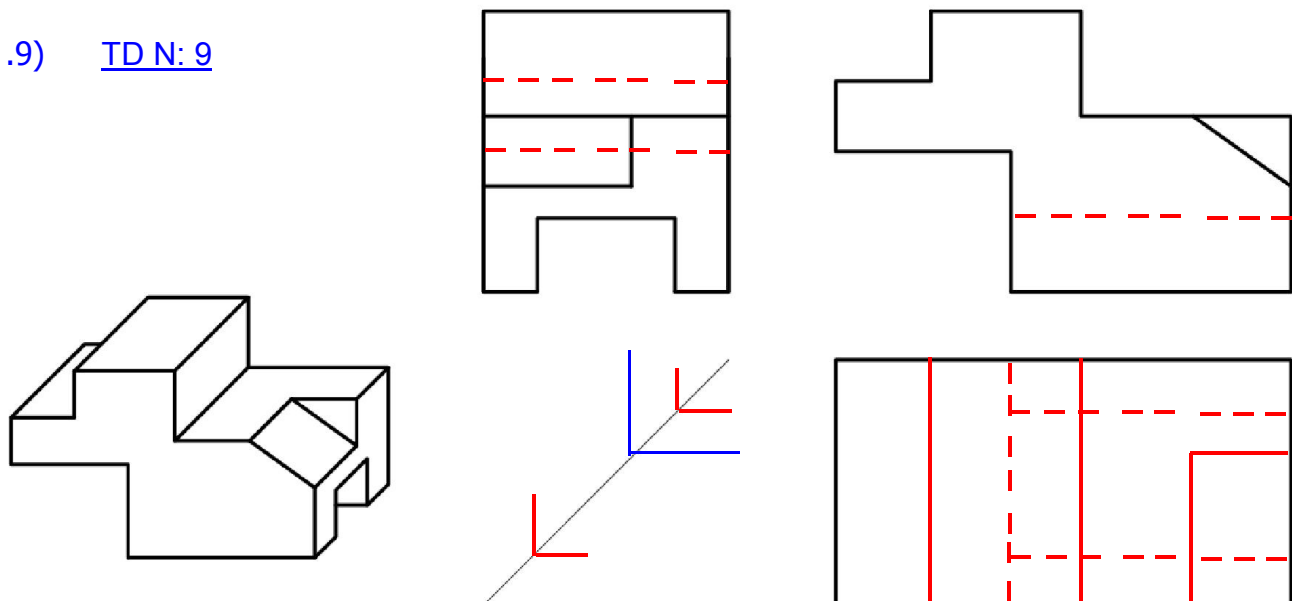

.10) [TD N: 10](#)

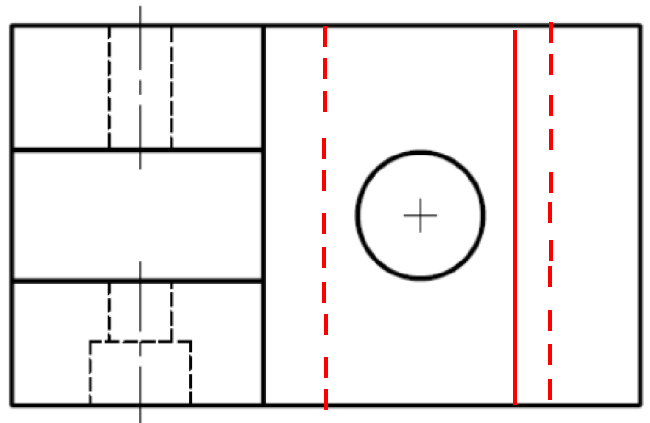
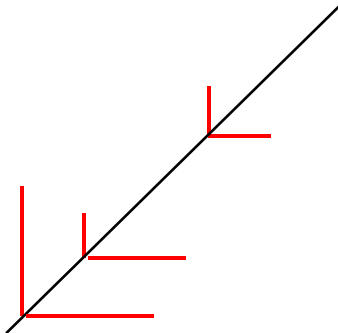
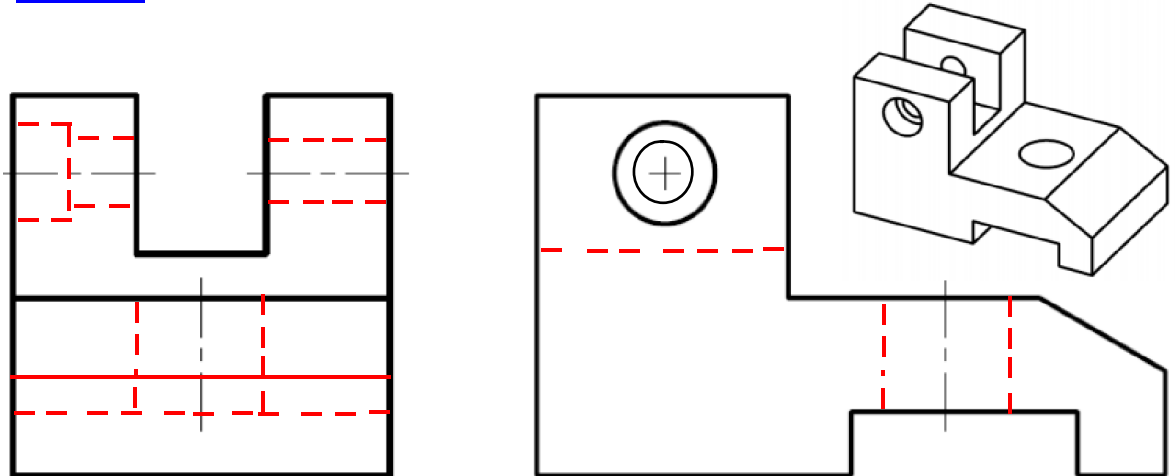

.11) [TD N: 11](#)

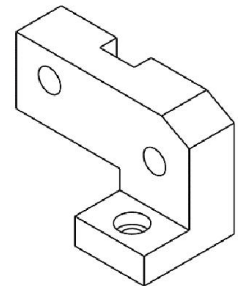
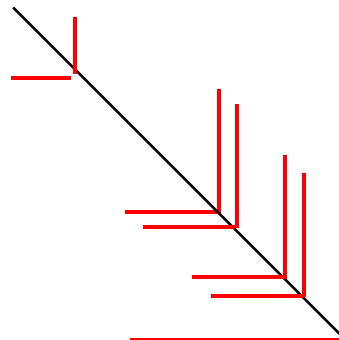
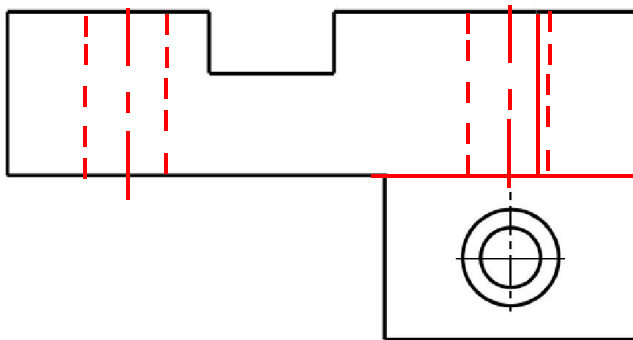
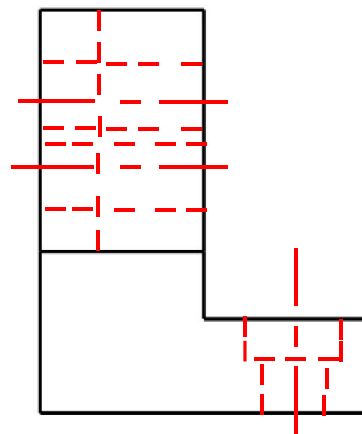
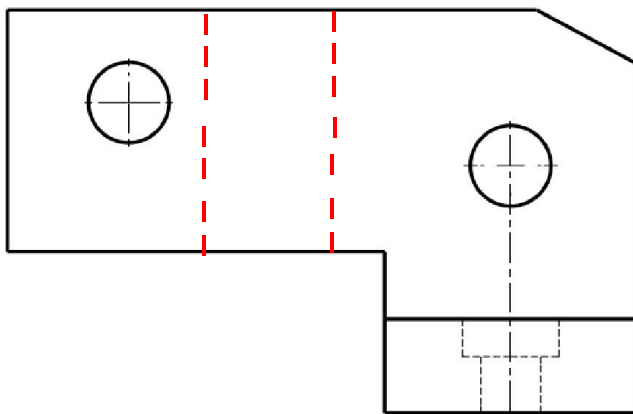

.12) TD N: 12

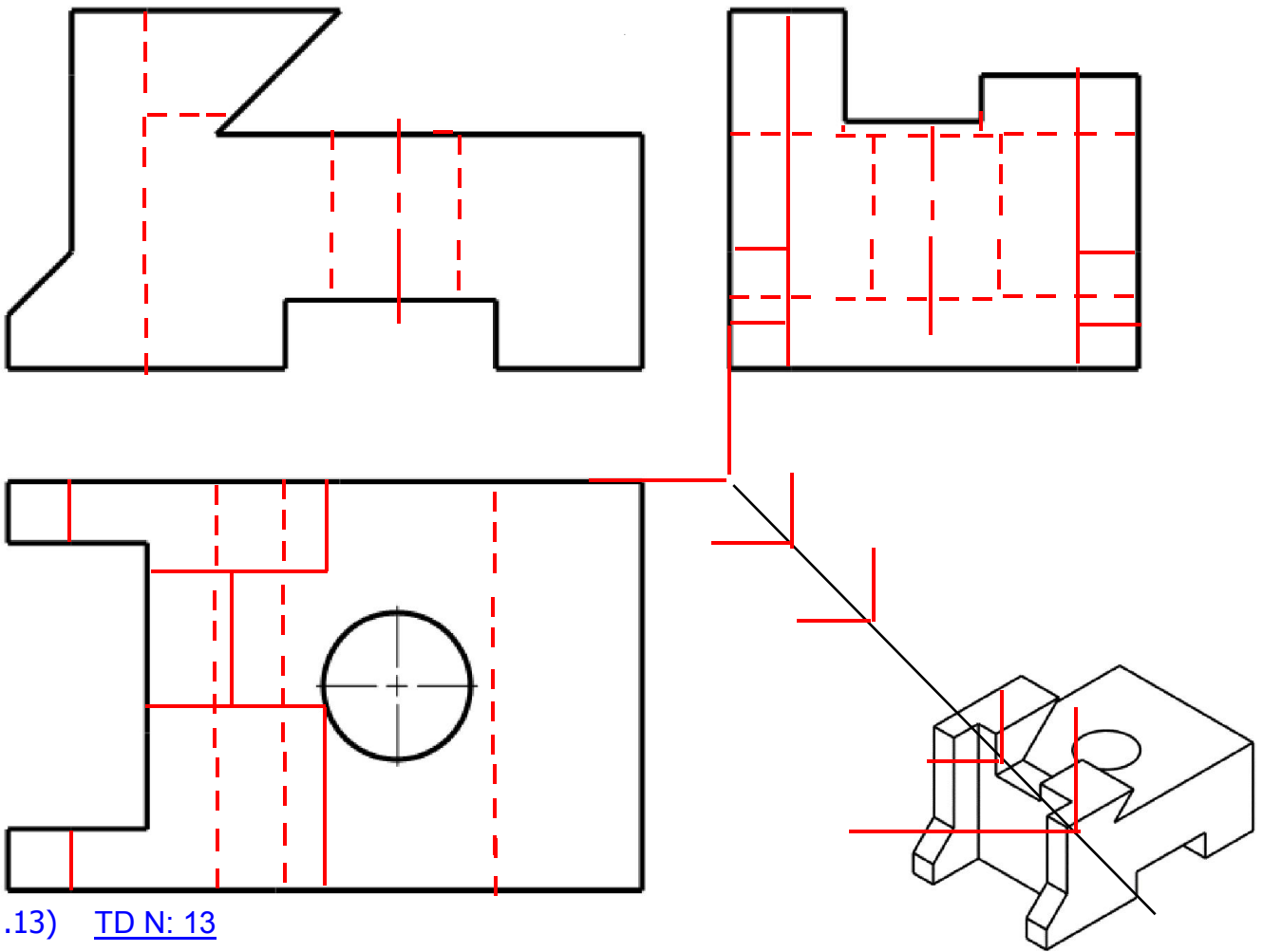

.13) TD N: 13

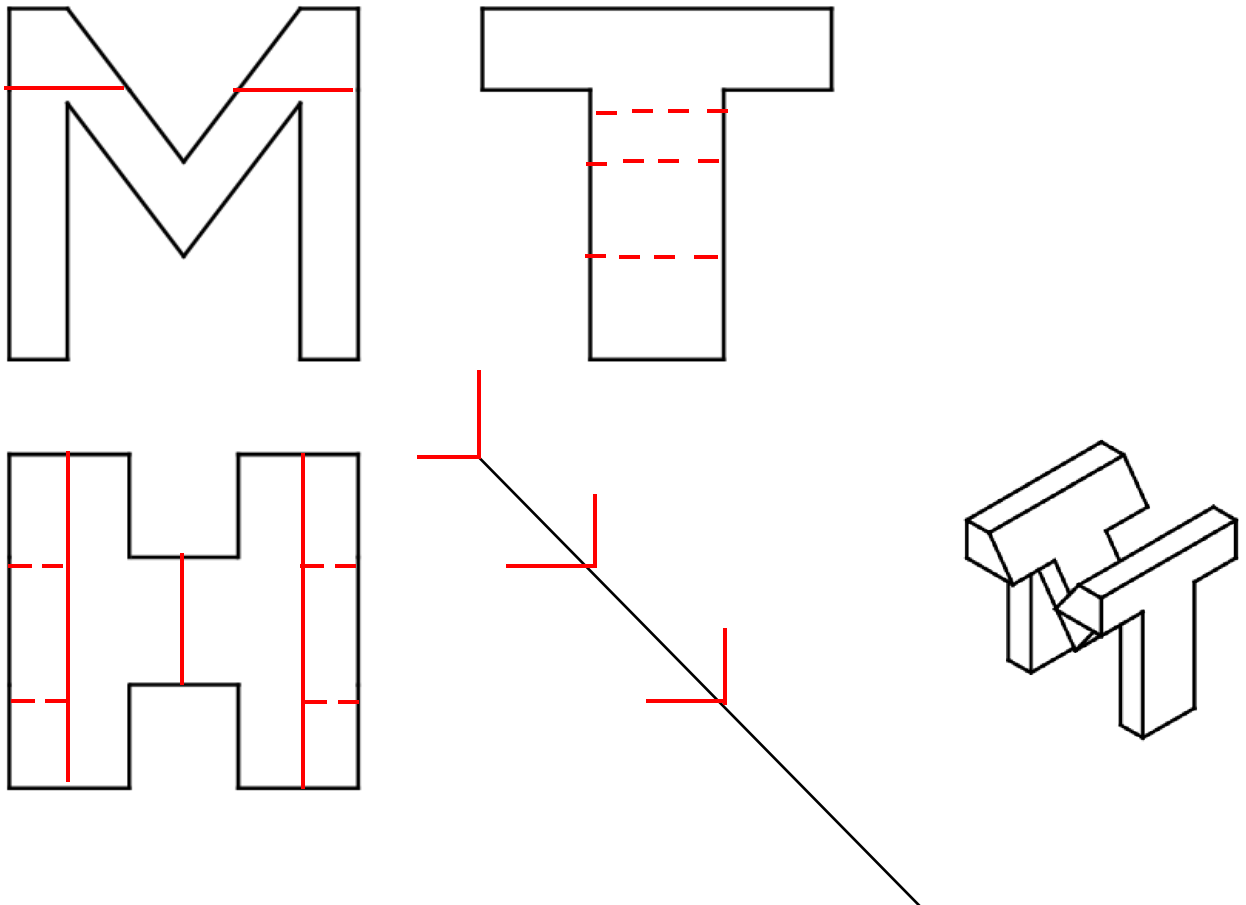

.TD N: 14

CORRECTION

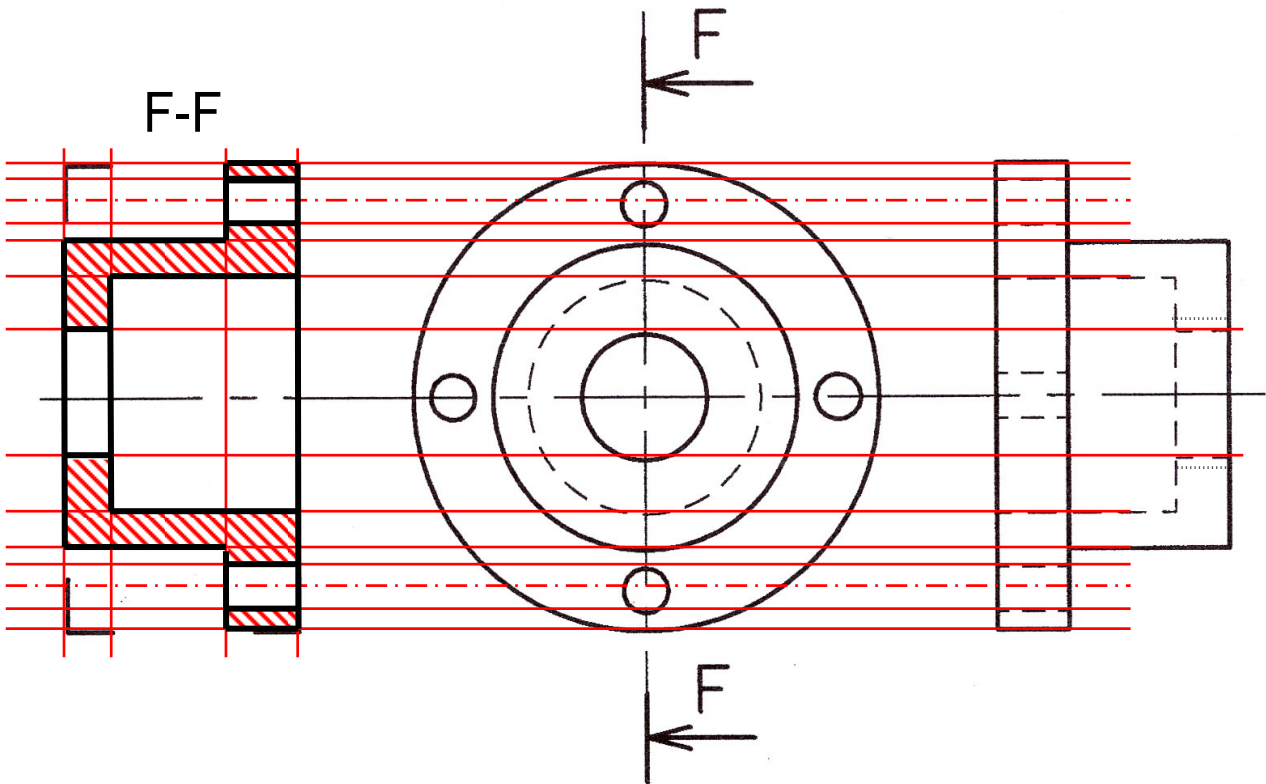
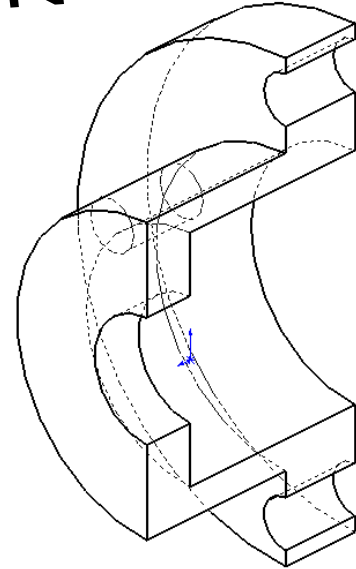
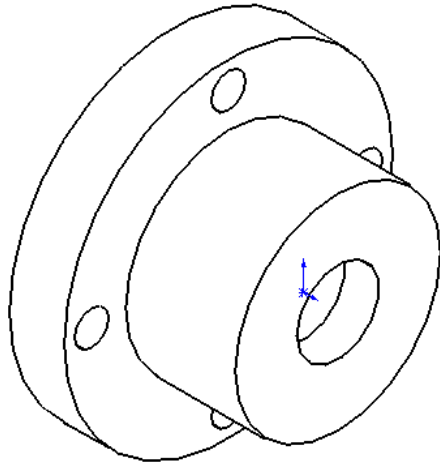

.TD N: 15

CORRECTION

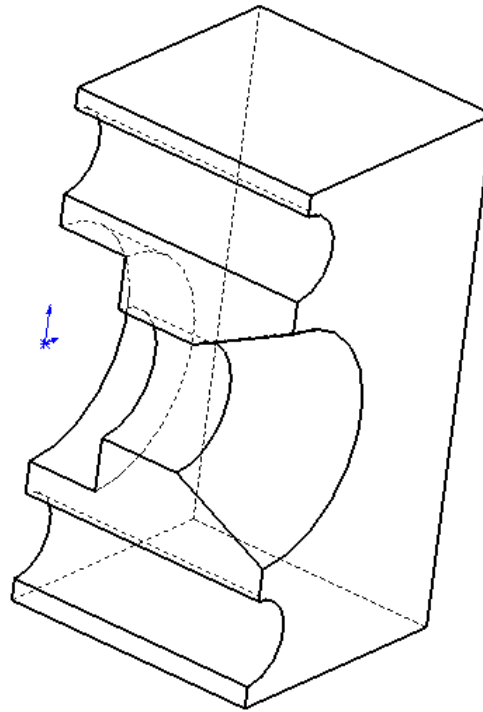
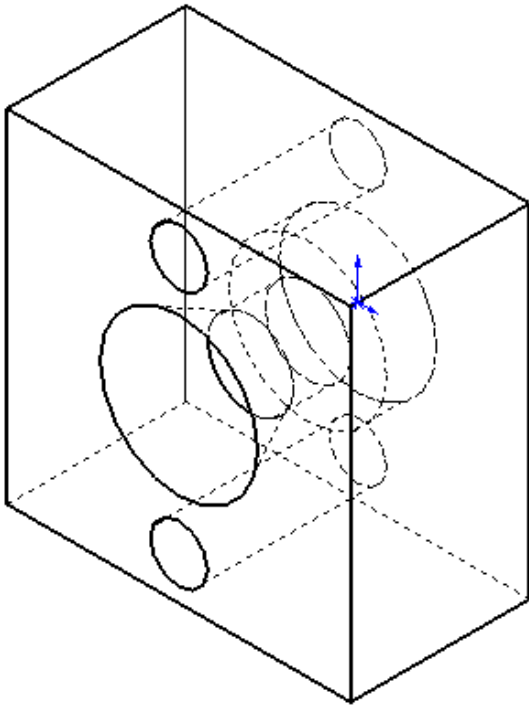

Coupe G-G

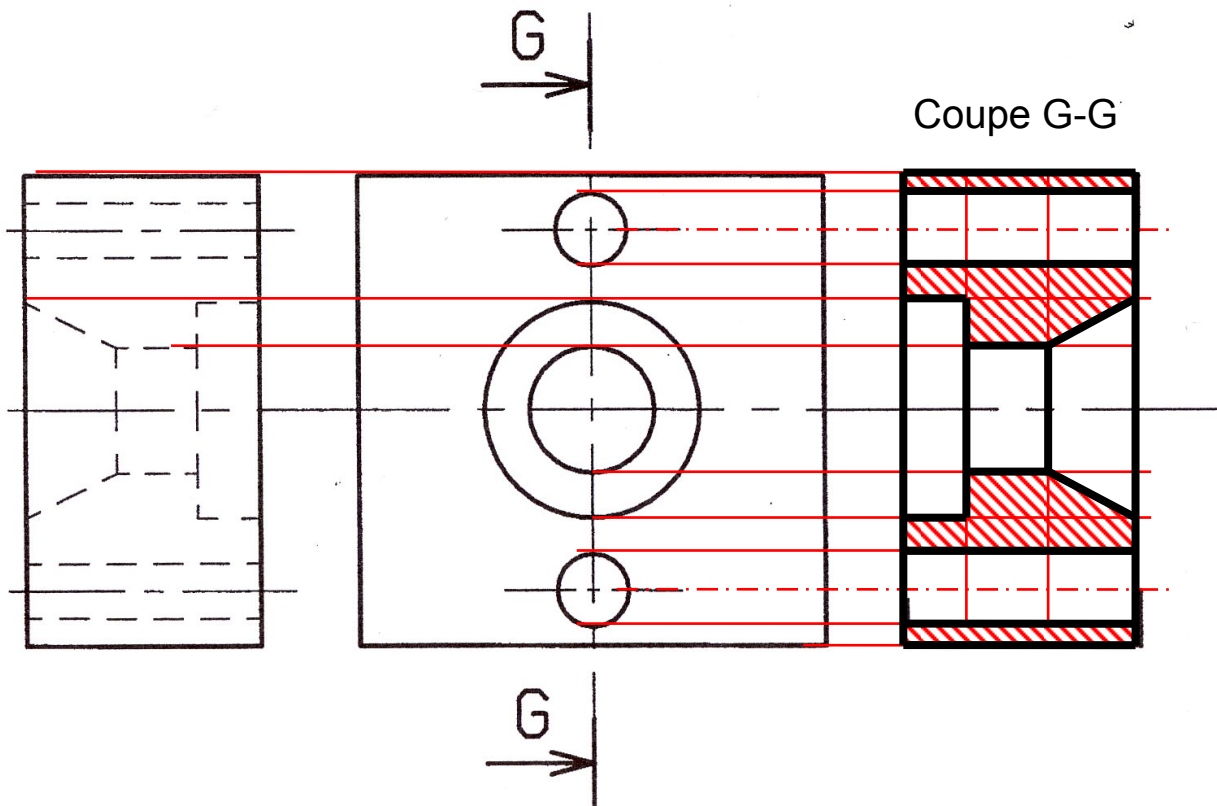

.TD N: 16

CORRECTION

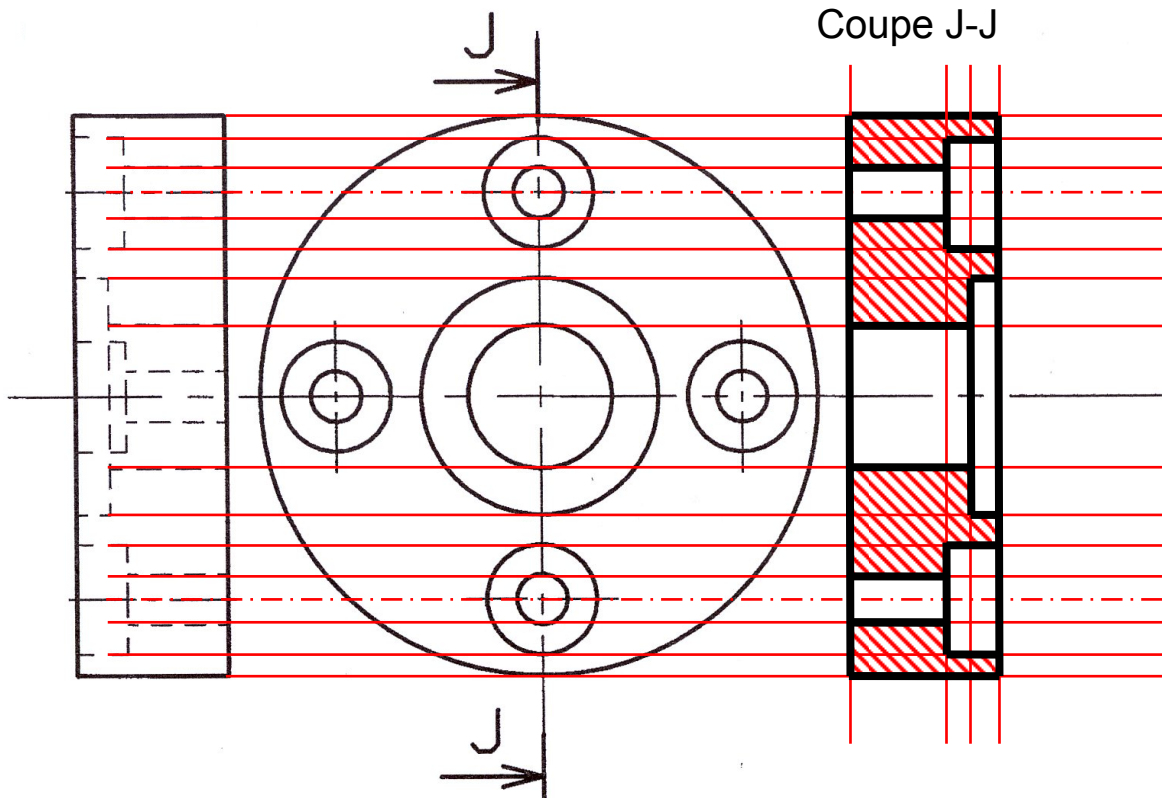
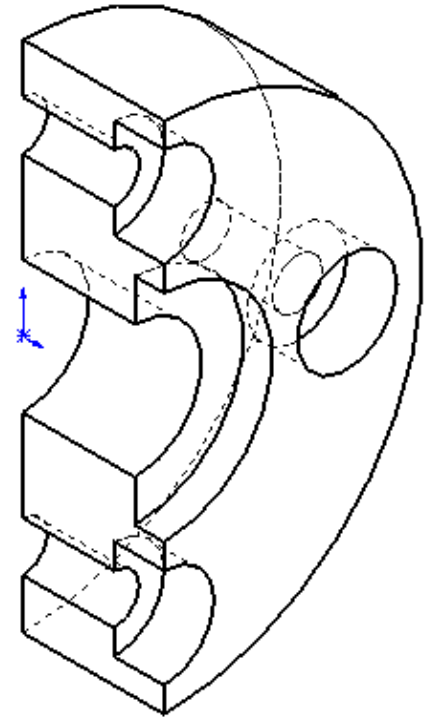
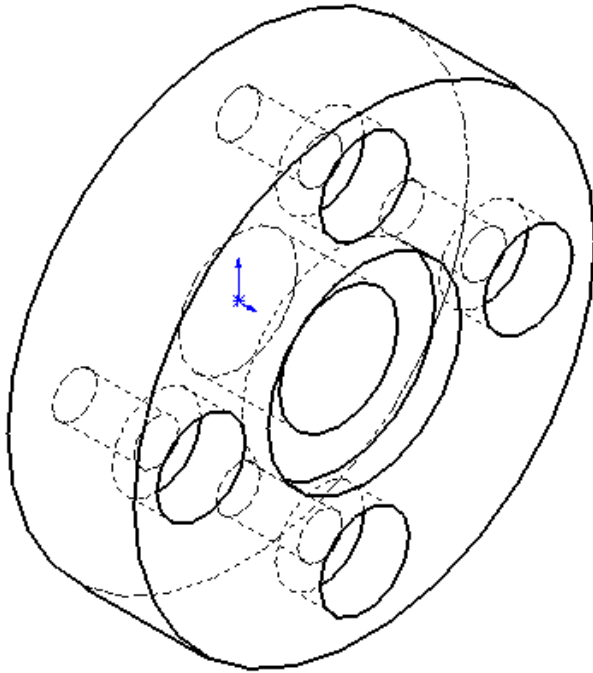

TD N: 17

CORRECTION

Compléter la section H-H le de cette piece .

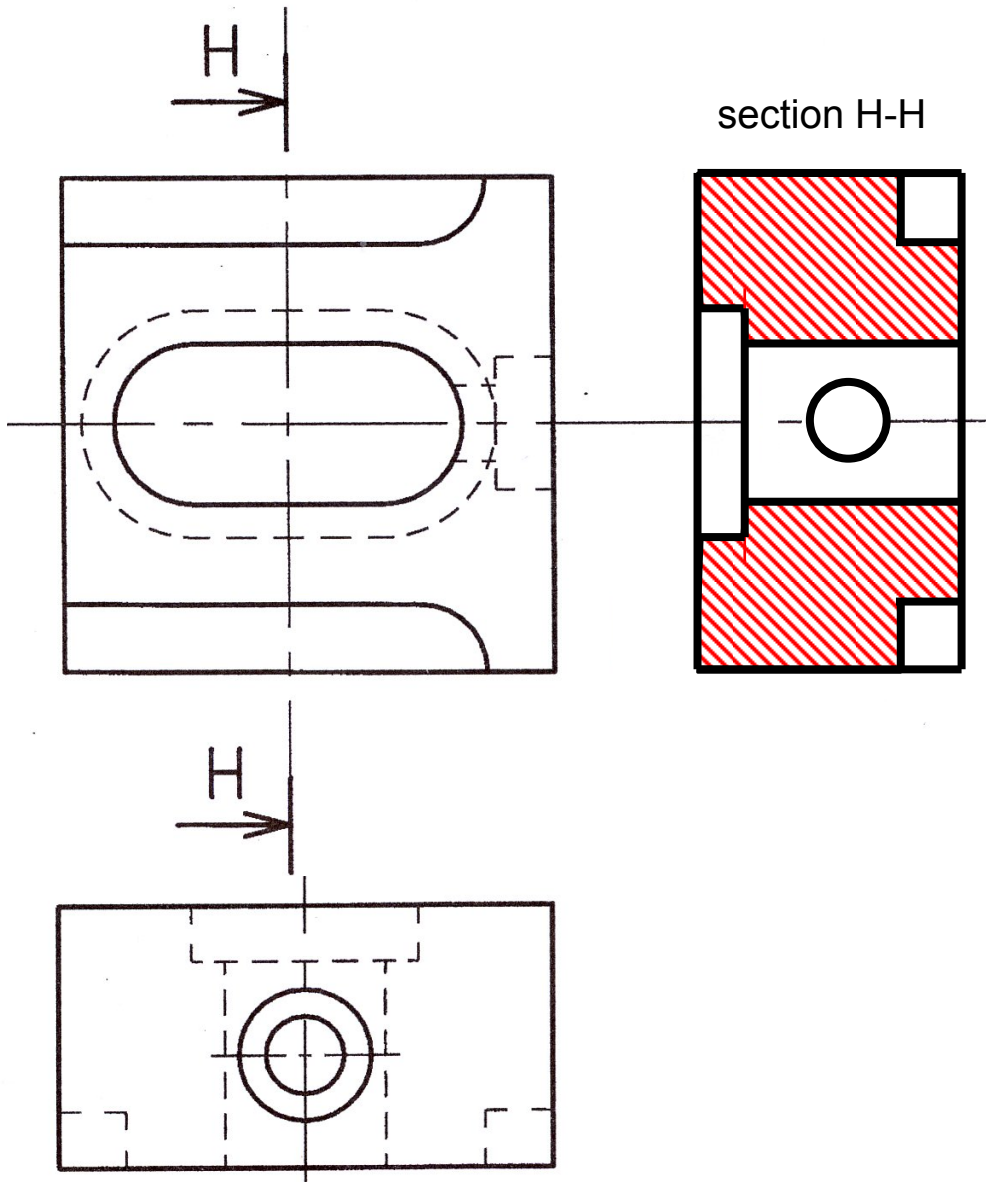
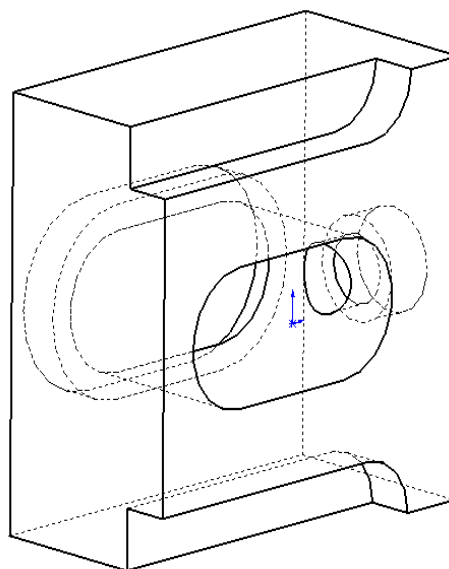

.TD N: 18

الامتحان الوطني الموحد للبكالوريا
الدورة العادية 2021

- Compléter le dessin de la chape en :

- Vue de droite en coupe B-B (Ne pas représenter les formes cachées).
- Vue de dessus en coupe A-A (Représenter les formes cachées).

/2,25

Vue 3D de la chape

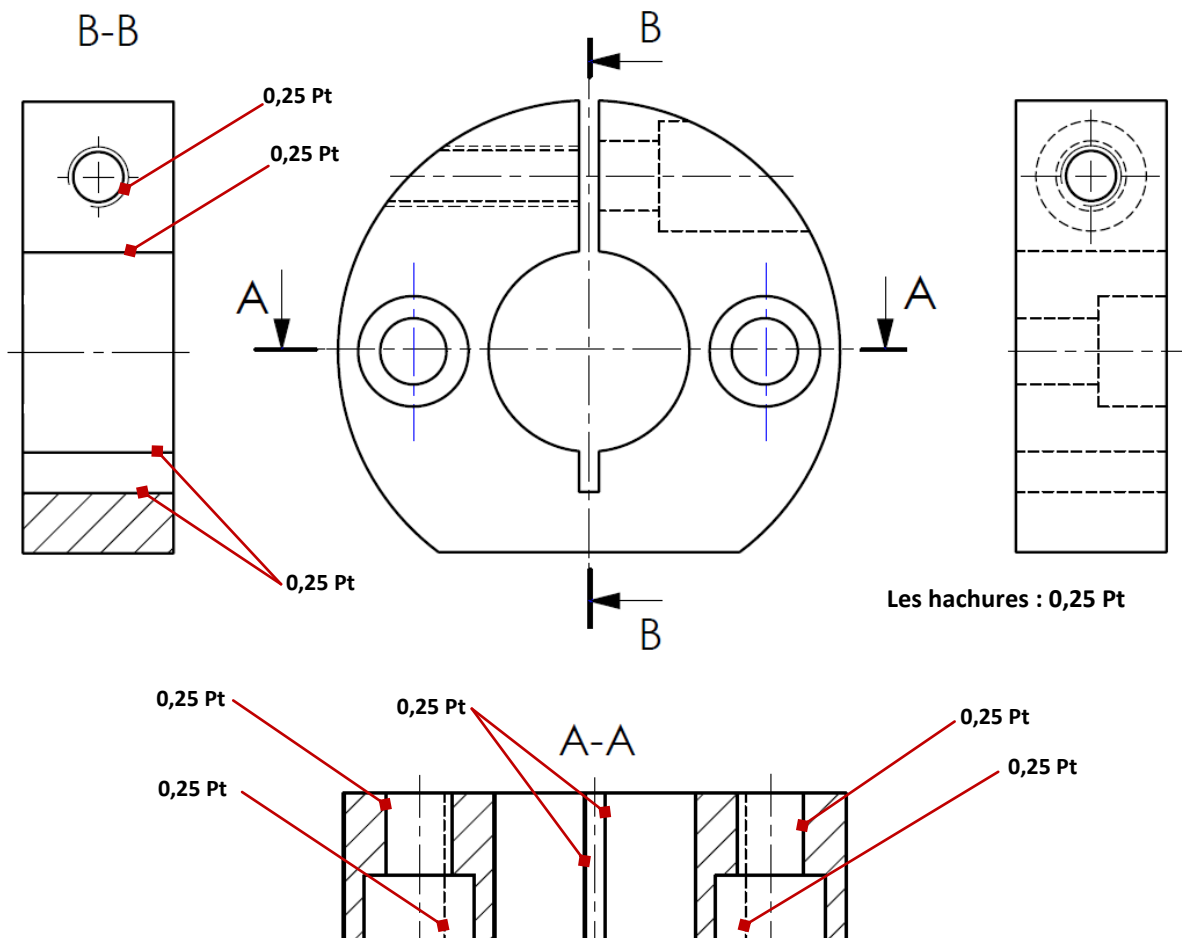
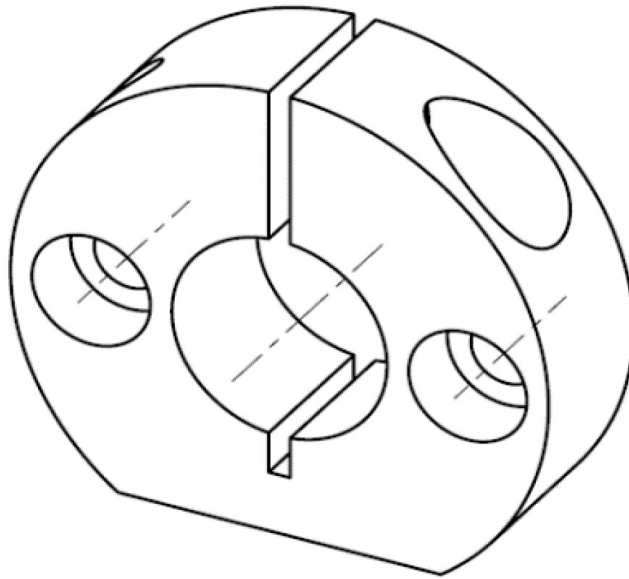

الامتحان الوطني الموحد للبكالوريا
الدورة الاستدراكية 2021

.TD N: 19

- Représenter la pièce (11) en vue de face coupe A-A en respectant la cotation.

2,00 pts

Pièce (11)

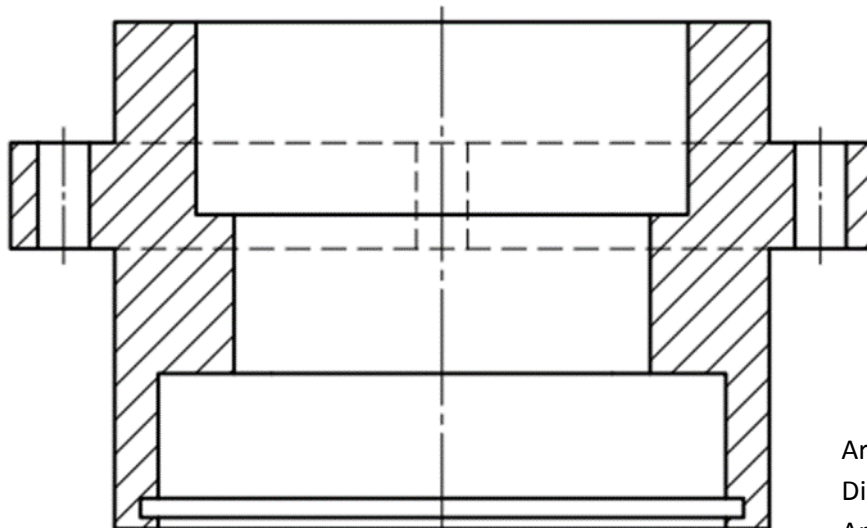
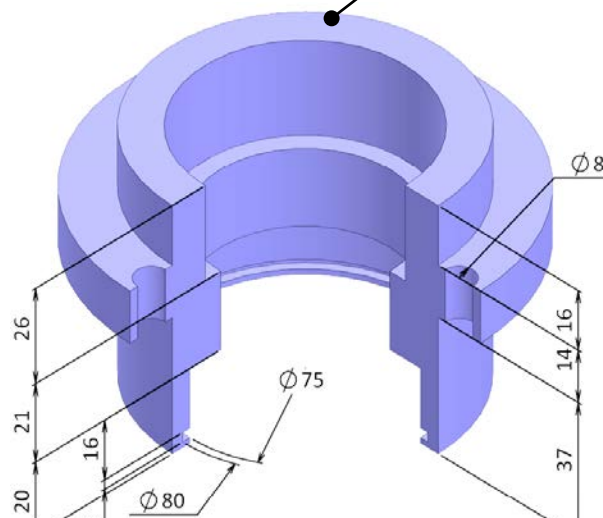

2,00 pts

Arrêtes vues : 0,5pt
Dimensions : 0,75pt
Arrêtes cachées : 0,5pt
Hachures : 0.25pt

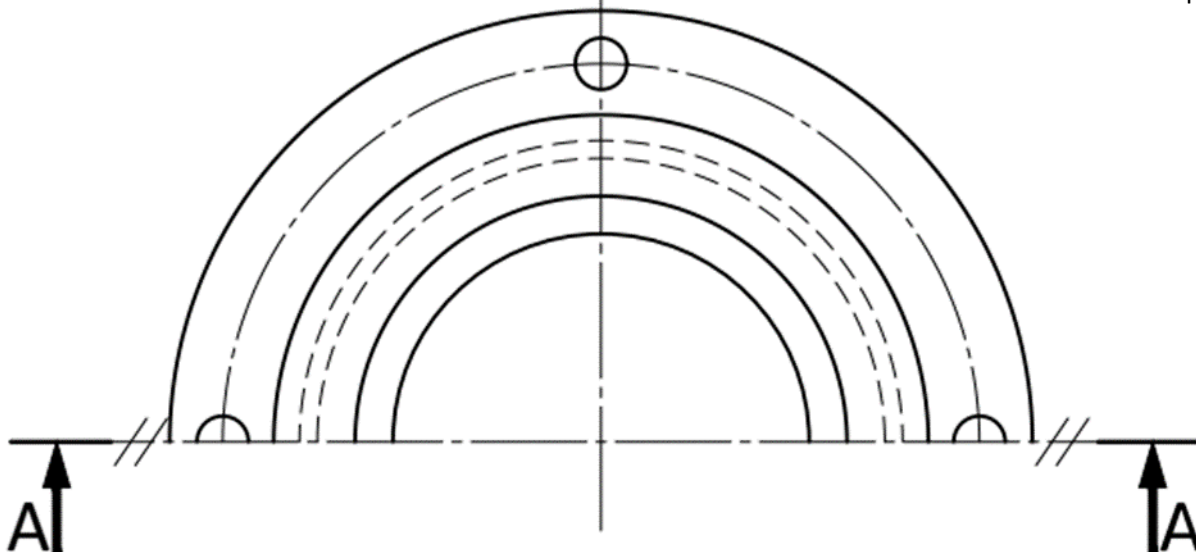

الامتحان الوطني الموحد للبكالوريا

الدورة العادية 2020

TD N: 20

Compléter les vues suivantes du dessin de la chape montée sur la tige du vérin :

(Représenter toutes les formes cachées)

- La vue de gauche en coupe A-A.
- La vue de dessus.

Dessin 3D de la Chape montée sur la tige du vérin

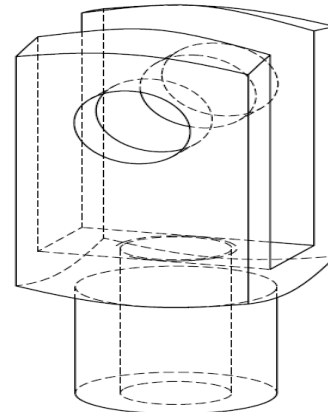

- Vue de dessus.

/2,25

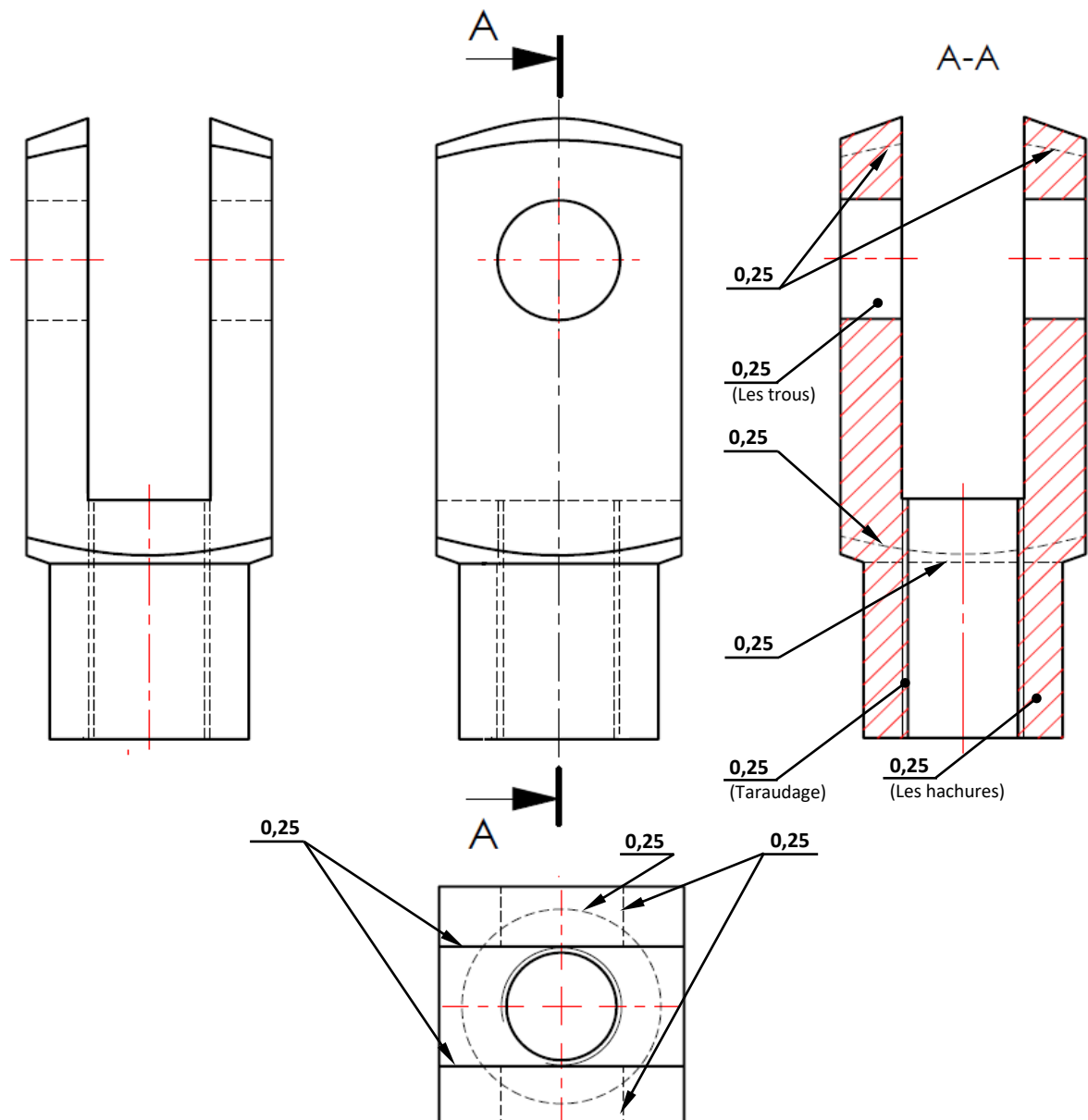

TD N: 21

الامتحان الوطني الموحد للبكالوريا الدورة الاستدراكية 2020

Q. Compléter le dessin de la **bride** solidaire de l'arbre du **vérin rotatif** en vue de gauche coupe A-A.
(Sans traits cachés)

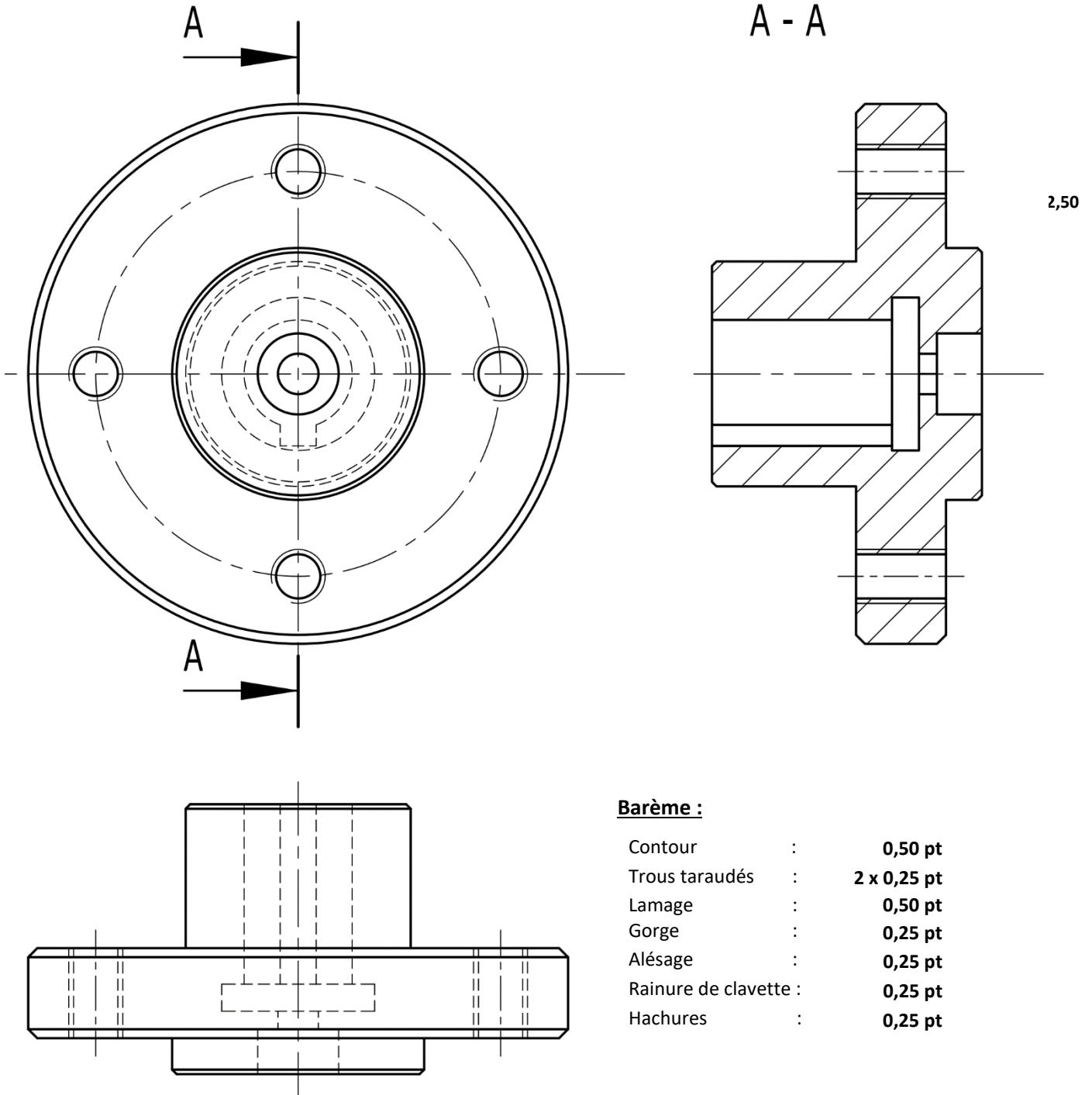
**Barème :**

Contour	:	0,50 pt
Trous taraudés	:	2 x 0,25 pt
Lamage	:	0,50 pt
Gorge	:	0,25 pt
Alésage	:	0,25 pt
Rainure de clavette	:	0,25 pt
Hachures	:	0,25 pt

الامتحان الوطني الموحد للبكالوريا
الدورة العادية 2019

TD N: 22

Compléter la vue de face en coupe A-A du dessin du support de rail lamé.

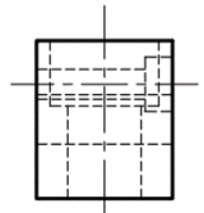
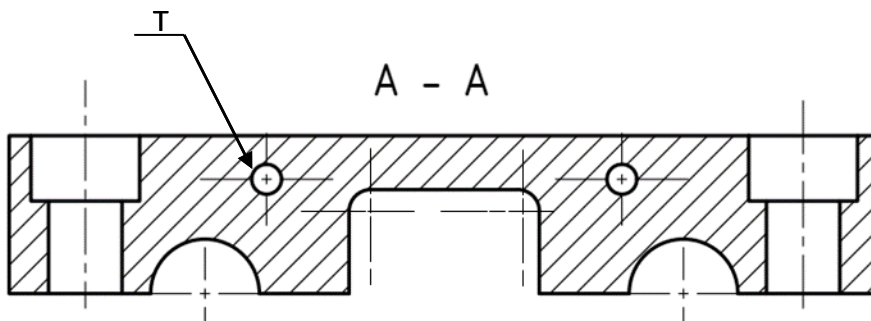
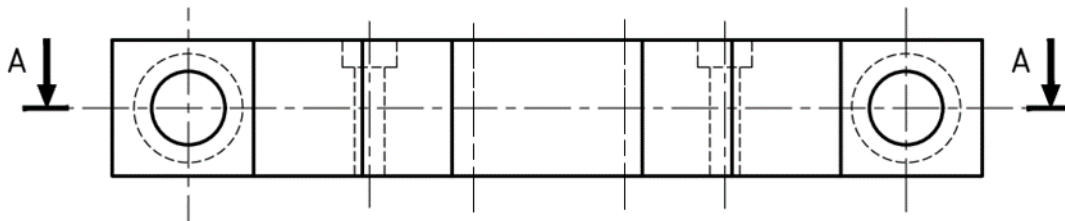
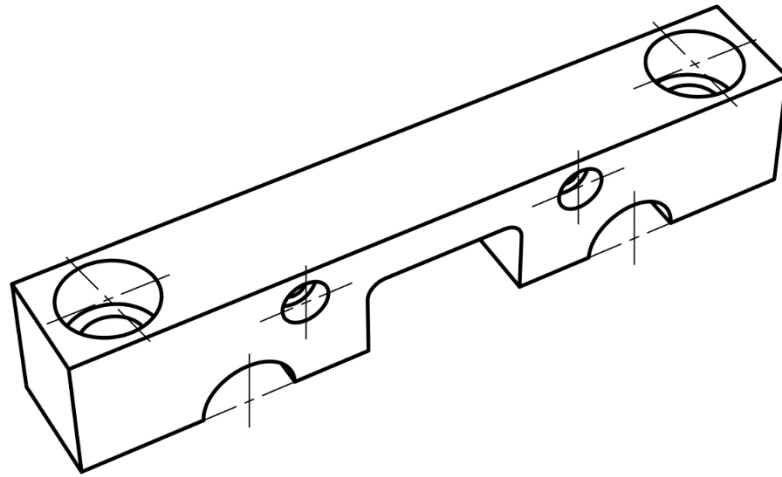
Vue en 3D du support de rail lamé seul

الامتحان الوطني الموحد للبكالوريا

TD N: 23

الدورة الاستدراكية 2019

Compléter la vue de gauche en coupe A-A de cet accouplement sans représenter les arêtes cachées. 2,00 pts

Représentation 3D du manchon de l'accouplement

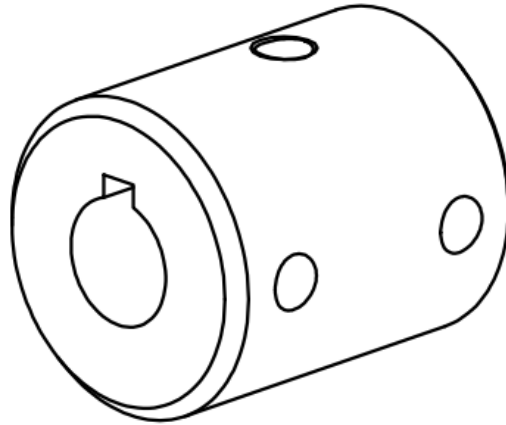

A-A

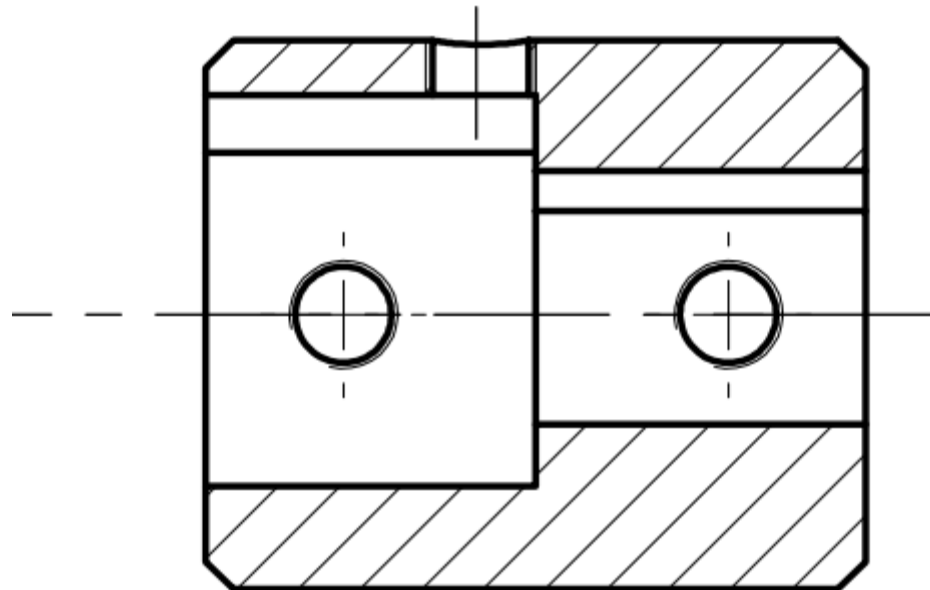

Coupe +hachure	/0,75 pt
Rainures	/0,50 pt
Tarudages	/ 0,5 pt
Repérage de la coupe	/0,25 pt

الامتحان الوطني الموحد للبكالوريا

TD N: 24

الدورة العادية 2022

Q.32. Compléter le dessin de la buse en :

2,50 pts

- Vue de face en coupe A-A.
- Vue de droite.

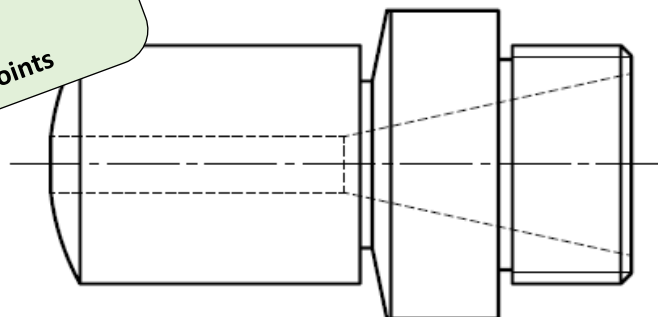
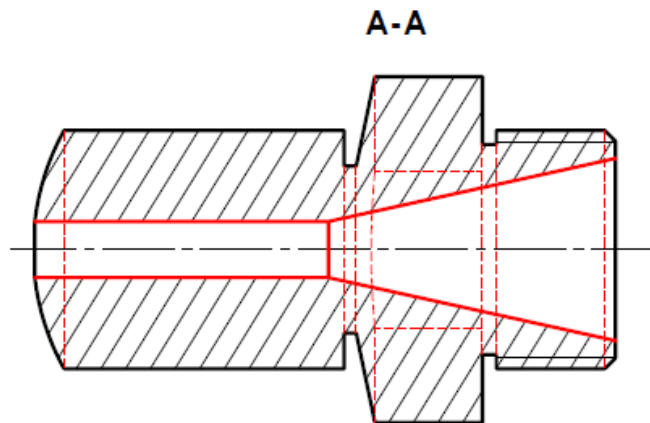
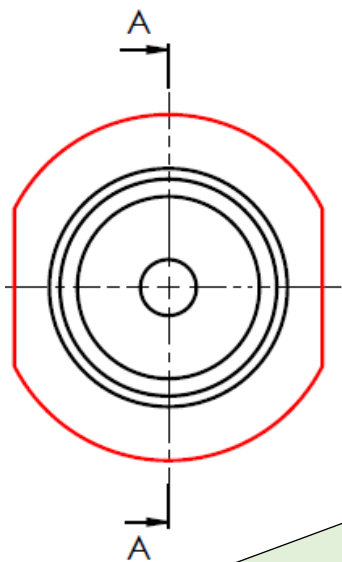
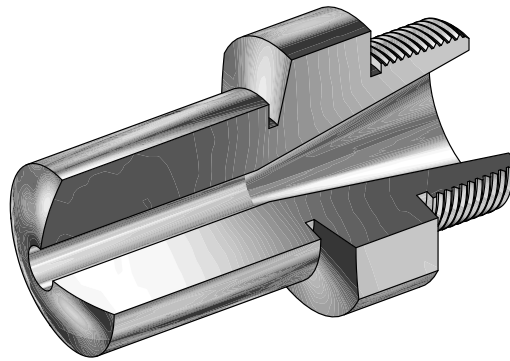
Nota : Voir le rendu 3D de la buse en 1/4 enlevé

Les hachures : 0,125
 Le filetage : 0,125
 18 traits : x 0,125 = 2,25 points

الامتحان الوطني الموحد للبكالوريا

TD N: 25

الدورة الاستدراكية 2022

Q.Représentation graphique de la pièce (3).

2,00 pts

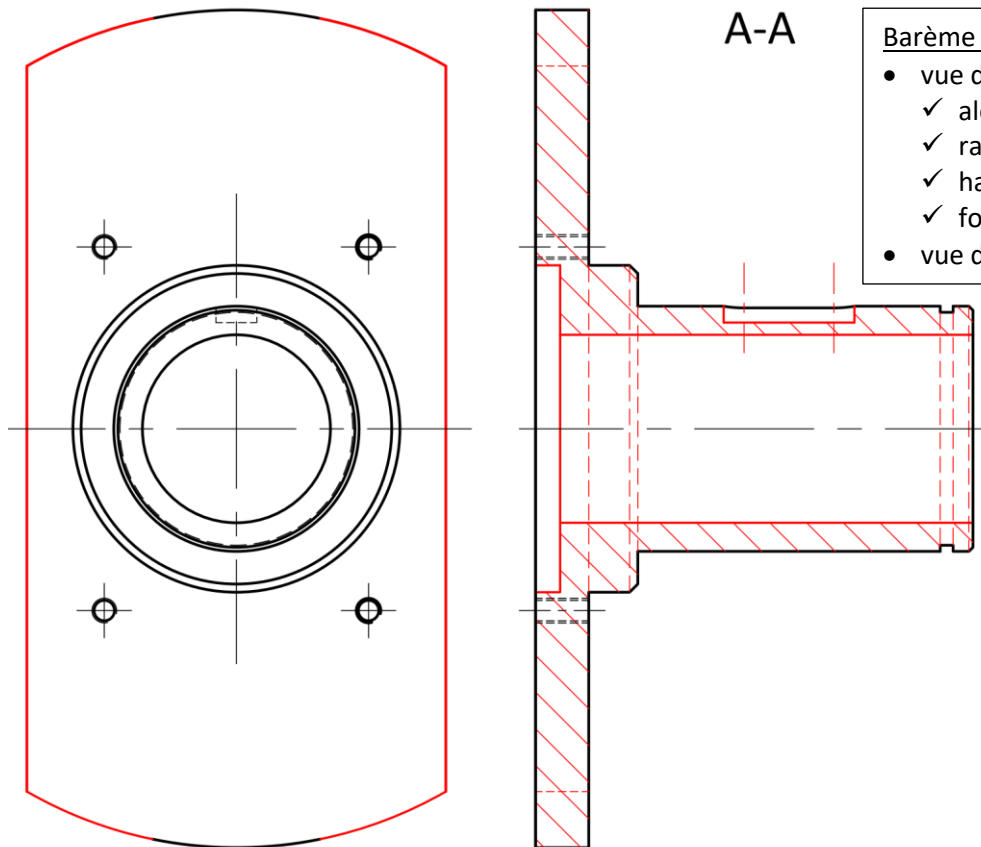

Barème :

- vue de face coupe A-A :
 - ✓ alésage + lamage : 0,5 pt
 - ✓ rainure : 0,25 pt
 - ✓ hachures : 0,25 pt
 - ✓ formes cachées : 0,50 pt
- vue de droite : 0,50 pt

